

## Why can't standard Somfy motors be wired in parallel?

Somfy operators are fitted with a single phase asynchronous motor type, which means that there is a capacitor between the two directional windings. When operators are wired in parallel, all directional wires are interconnected through the capacitors (shown in light red below), this produces interference between directions.

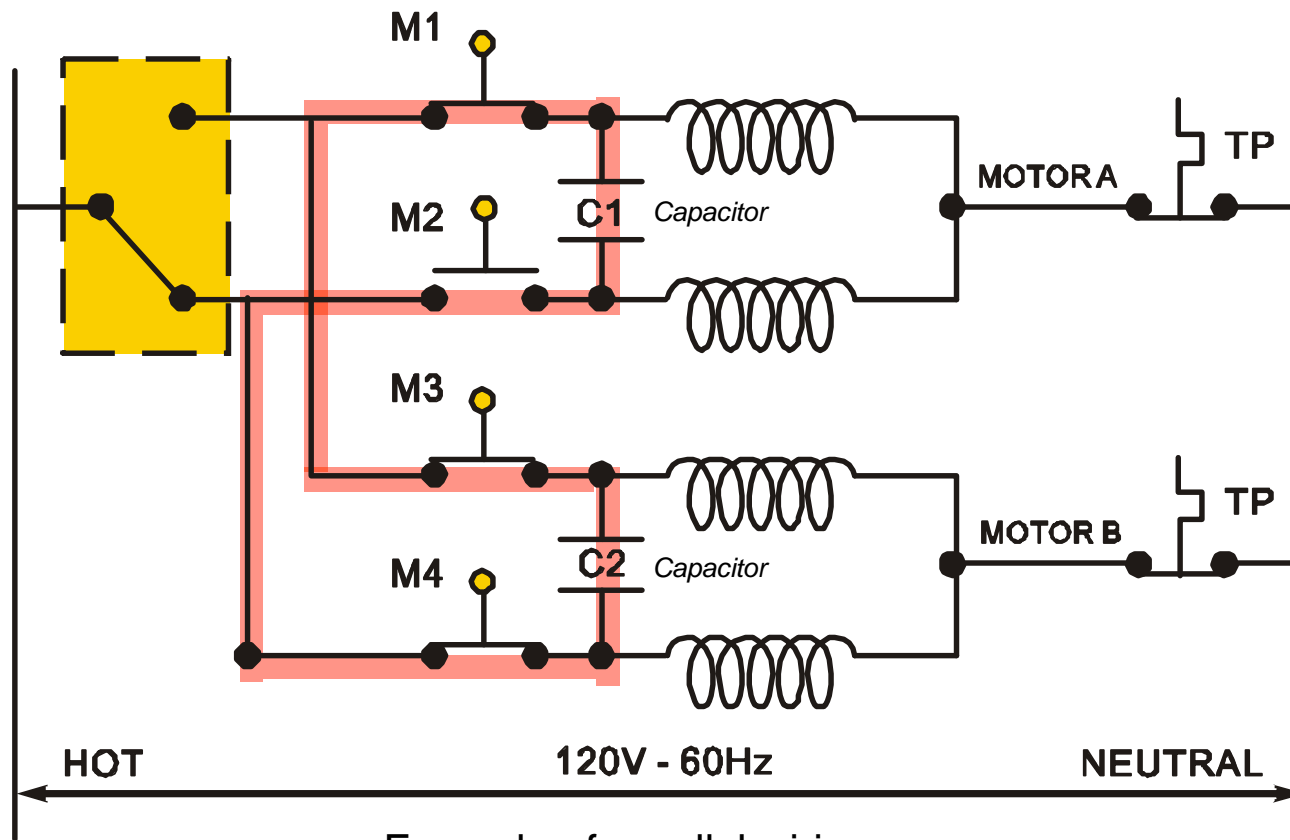

Example of parallel wiring

End product rapidly moving back and forth near their end limits is the sign of parallel wiring

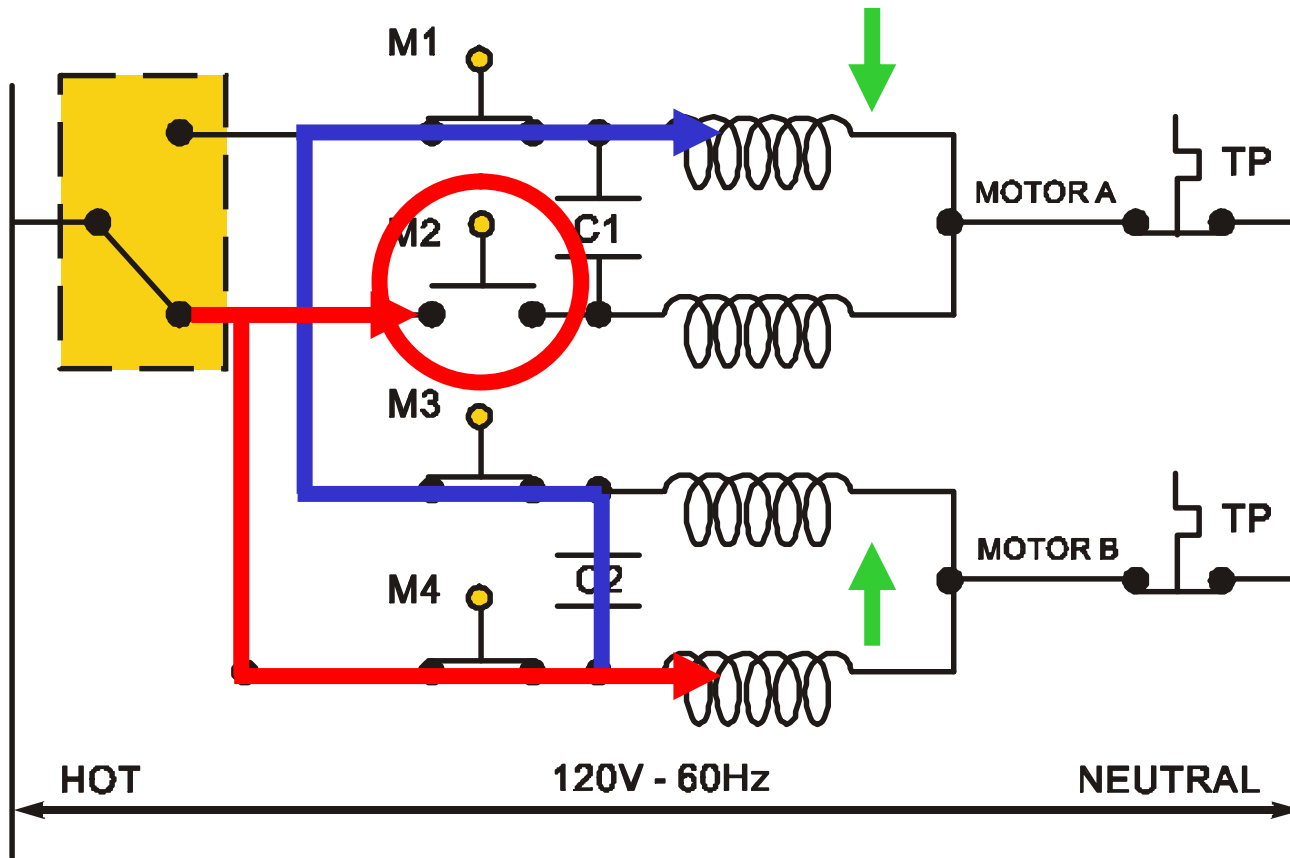

If Motor A reaches its upper limit before Motor B micro-switch M2 opens and the down direction of Motor A is powered through capacitor C2 (blue line), then reverses direction and that rapid  cycle continues on Motor A until Motor B reaches its upper limit. This could ultimately damage the micro-switches or/and the brake or/and the end product.

To avoid that problem use DPDT switches or controls with separated relays such as IGC and GCS

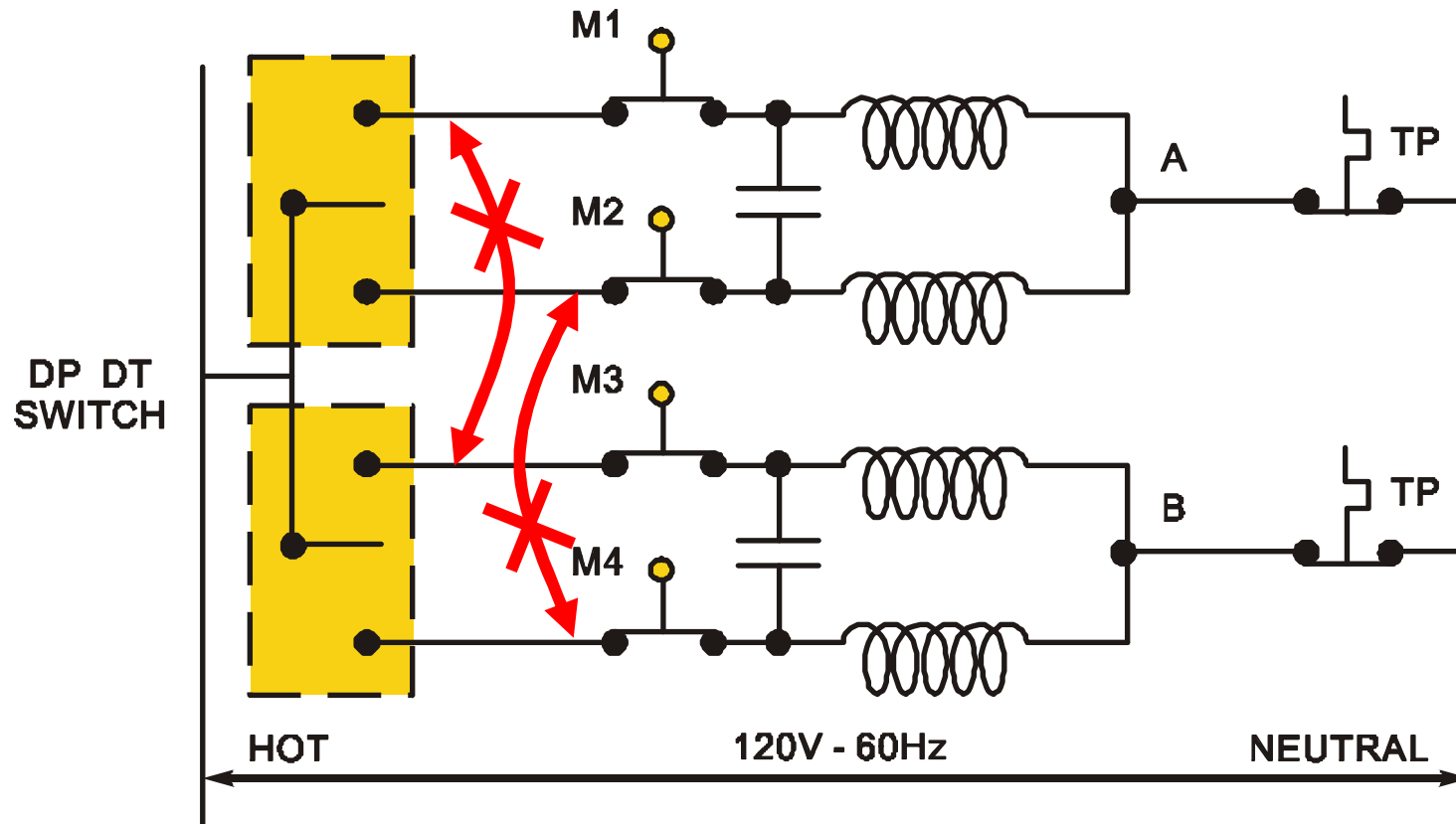

Parallel Wiring voids  
the Somfy Warranty