

FPC STEEL COUNTER DOOR

Advantages

Made in Canada for Canadian conditions.

Rugged 2" flat slats.

10" brackets on all size doors (minimal headroom required).

For all wall types (concrete, masonry, structural steel, structural steel with gypsum board, gypsum wall partition with wood or metal studs).

Tubular bottom bar to conceal locking mechanisms.

Box-shaped guides for neat, clean appearance.

Features

2F flat slat curtain, 22ga. steel.

Corrosion resistant grey prime finish.

Oil tempered torsion springs high cycle life.

1 year warranty.

Options

Crank and bracket or wall mount motors.

Featheredge safety edge.

Power coat finish available in 180 standard colours.

Benefits

Ease of installation.

Assures years of trouble free operation.

Best value for the price.

Compact & secure.



STEEL COUNTER DOOR DETAILS

TYPICAL DETAILS

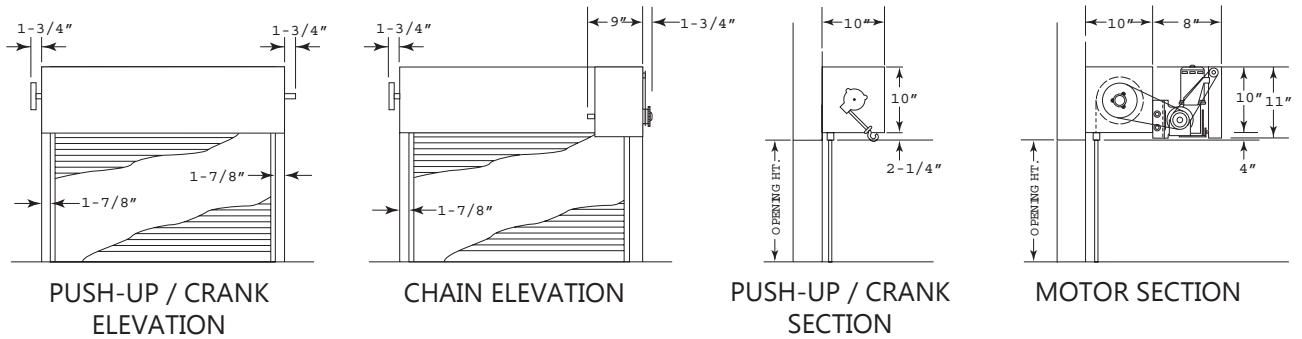

GUIDE DETAILS

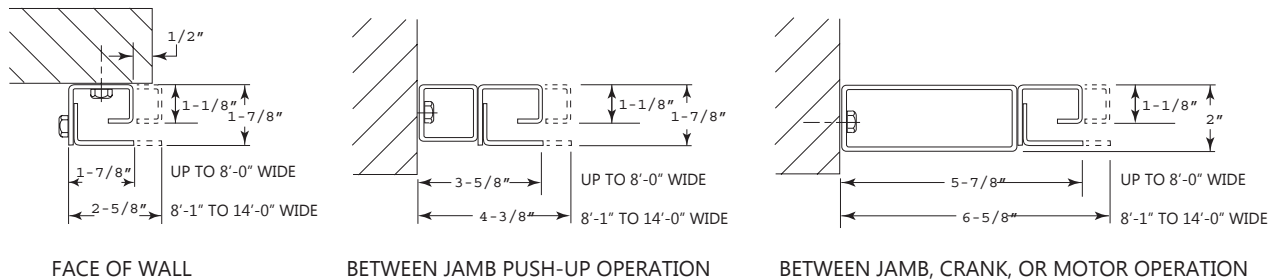

AREA CHART

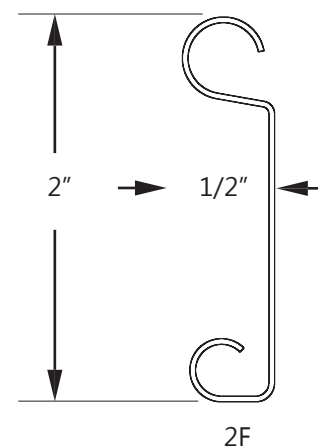
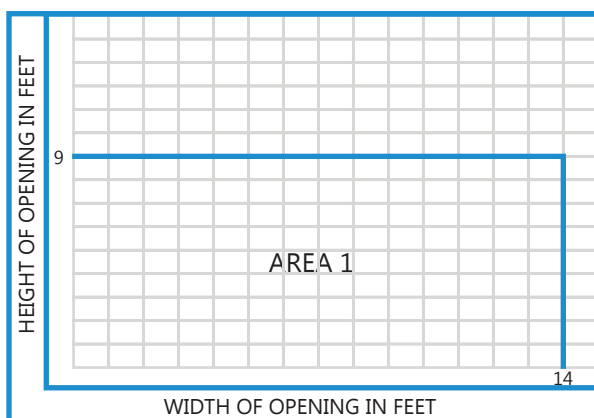

2F slats are available in sizes up to 14'-0" wide x 9'-0" high.

Contact SDI for larger doors.