Maintenance Manual

for

Manually & Motor Operated Fire Doors



1340 Midway Blvd
Mississauga, Ontario
Tel: 905-670-1200
Fax: 905-670-8830

Job Number _____

Job Name _____

This troubleshooting manual has been specifically written to provide a concise source of information to all customers of Service Door Industries. This information will provide solutions to the most common problems and establish a systematic sequence required to repair a rolling door.

PURPOSE

When a problem is encountered that is not covered in this manual, please consult Service Door Industries.

CUSTOMER SERVICE

Amazing Roller Shutters — 1-888-779-7731

When requesting information or ordering replacement parts, you must provide the following information.

ITEM

1. Job Number
2. Door Hand
3. Operator Voltage & Phase
4. Operator Model Number
5. Job Location

NOTE:

For maintenance or repair of this door, please consult your local authorized Distributor.

**PARTS LIST:
FACE MOUNTED,
PUSH-UP OPERATED
FIRE DOOR**

NO.	ITEM
1	Hood
2	Tension Spring
3	Tension Bracket
4	Barrel
5	Drive Side Tension Wheel
6	Drive Bracket
7	Tension Side Tension Wheel (if required)
8	Curtain
9	Guides
10	Bottom Bar
11	Stops
12	Fusible Link Assembly

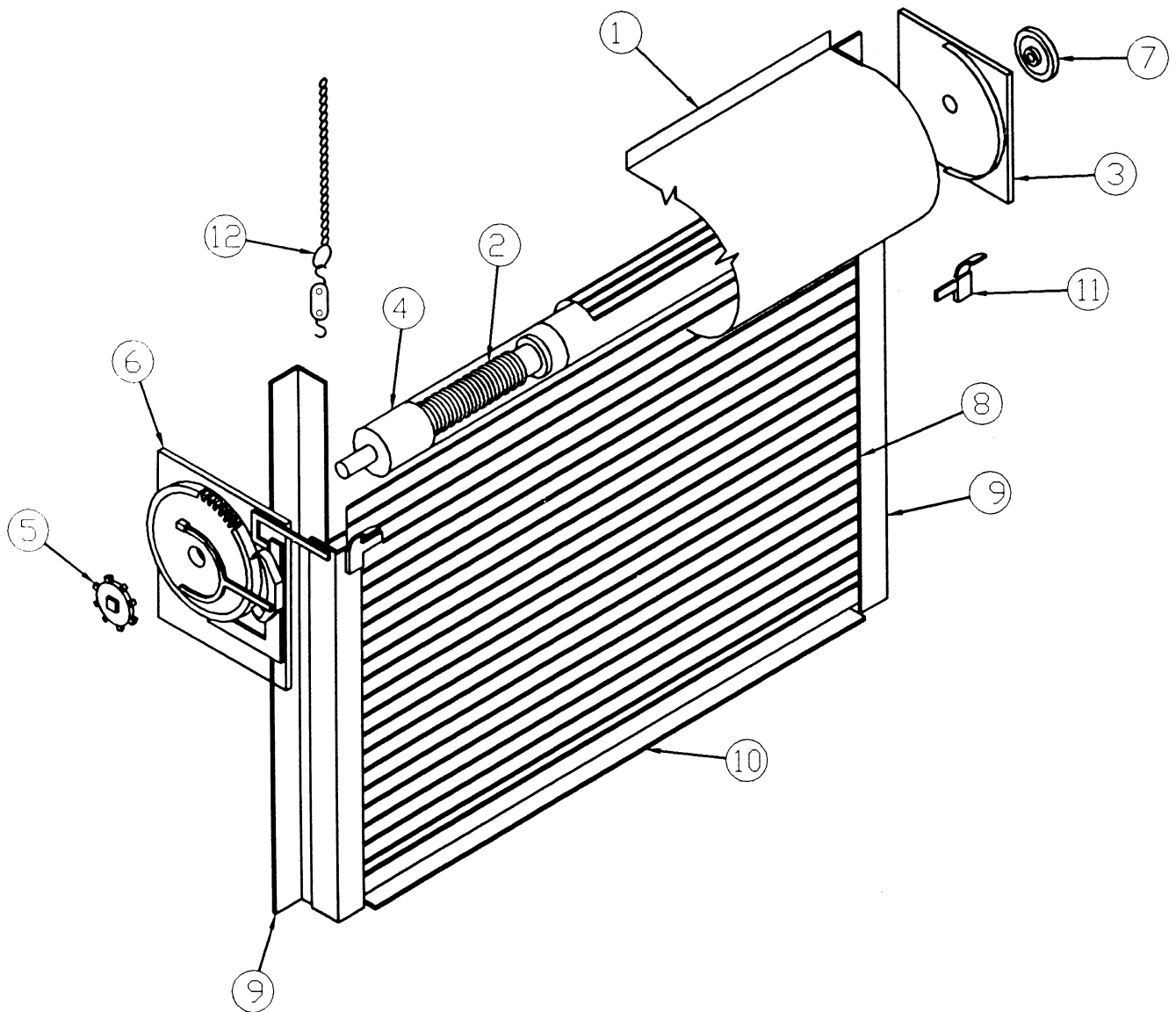

NO.	ITEM
1	Hood
2	Tension Spring
3	Tension Bracket
4	Barrel
5	Drive Side Tension Wheel (if required)
6	Chain Operator
7	Drive Bracket

NO.	ITEM
8	Tension Side Tension Wheel
9	Curtain
10	Guides
11	Bottom Bar
12	Stops
13	Hood Support (if required)
14	Fusible Link Assembly

**PARTS LIST:
FACE MOUNTED,
CHAIN OPERATED
FIRE DOOR**

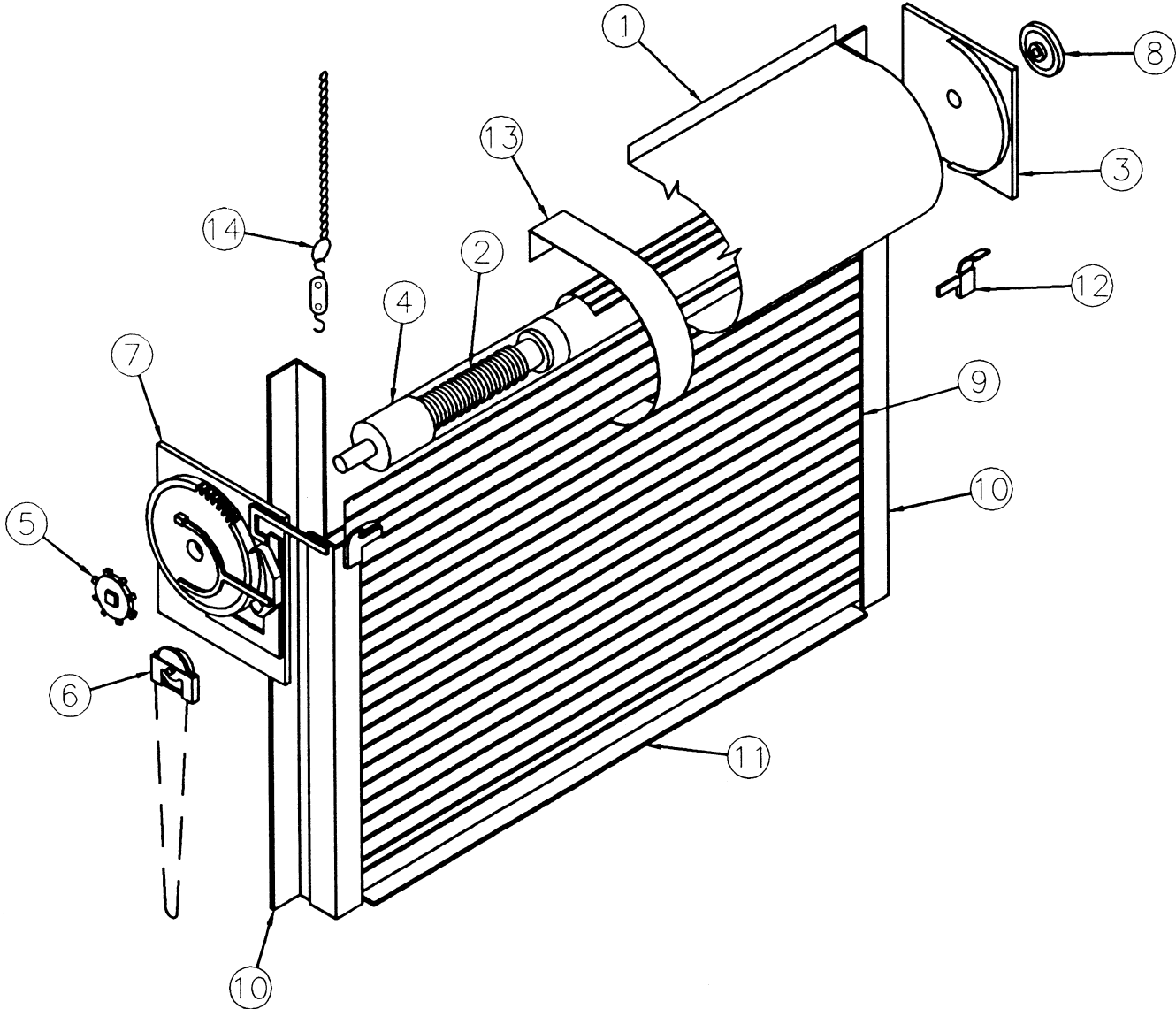

NOTE:
For maintenance or repair
of this door, please consult
your local authorized
Distributor.

**PARTS LIST:
FACE MOUNTED,
CRANK OPERATED
FIRE DOOR**

NO.	ITEM
1	Hood
2	Tension Spring
3	Tension Bracket
4	Barrel
5	Drive Side Tension Wheel
6	Crank Operator
7	Drive Bracket

NO.	ITEM
8	Tension Side Tension Wheel
9	Curtain
10	Guides
11	Bottom Bar
12	Stops
13	Hood Support (if required)
14	Fusible Link Assembly

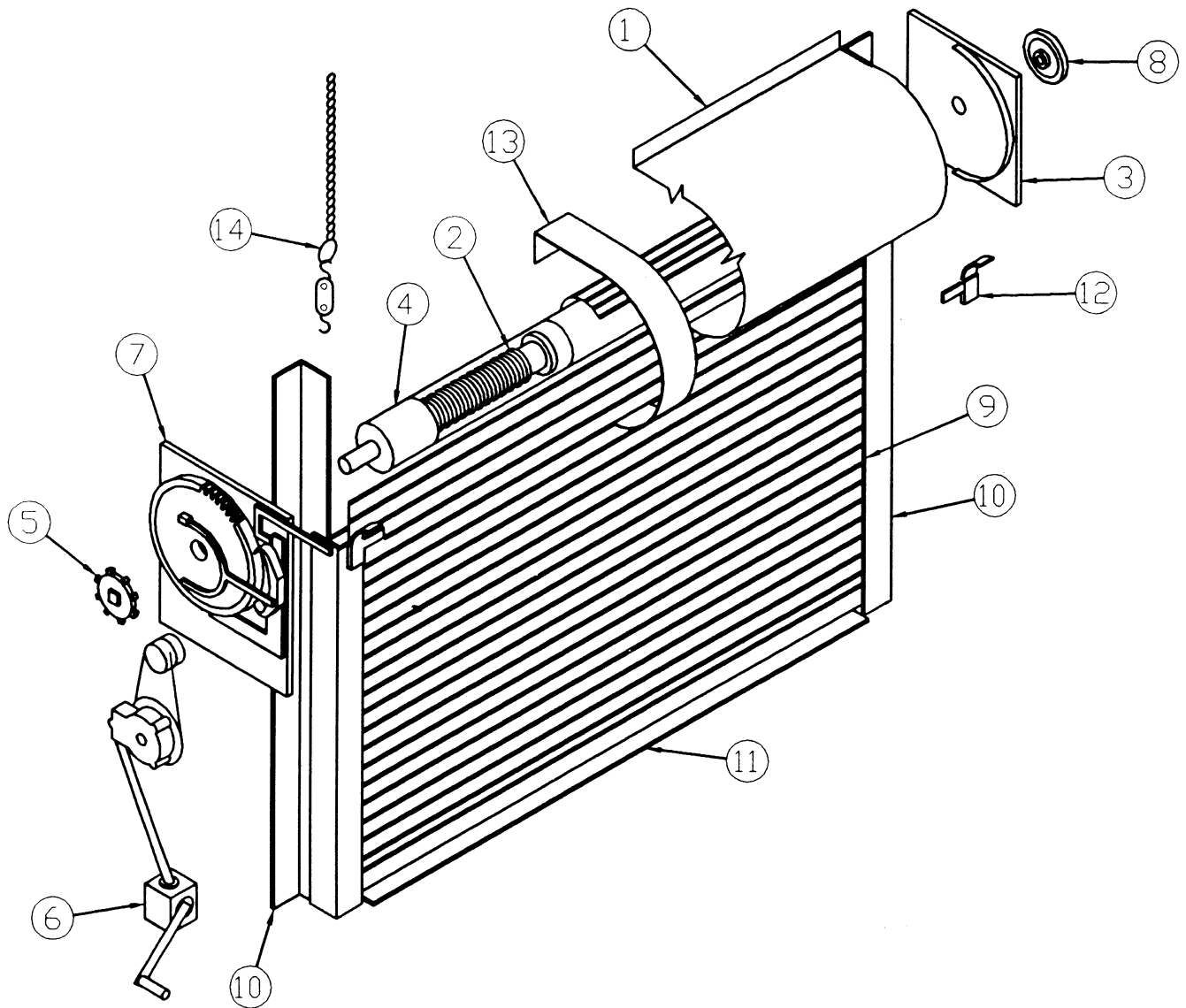

**PARTS LIST:
JAMB MOUNTED,
PUSH-UP OPERATED
FIRE DOOR**

NO.	ITEM
1	Hood
2	Tension Spring
3	Tension Bracket
4	Barrel
5	Drive Side Tension Wheel
6	Drive Bracket
7	Tension Side Tension Wheel (if required)
8	Curtain
9	Guides
10	Bottom Bar
11	Flare Stops
12	Fusible Link Assembly

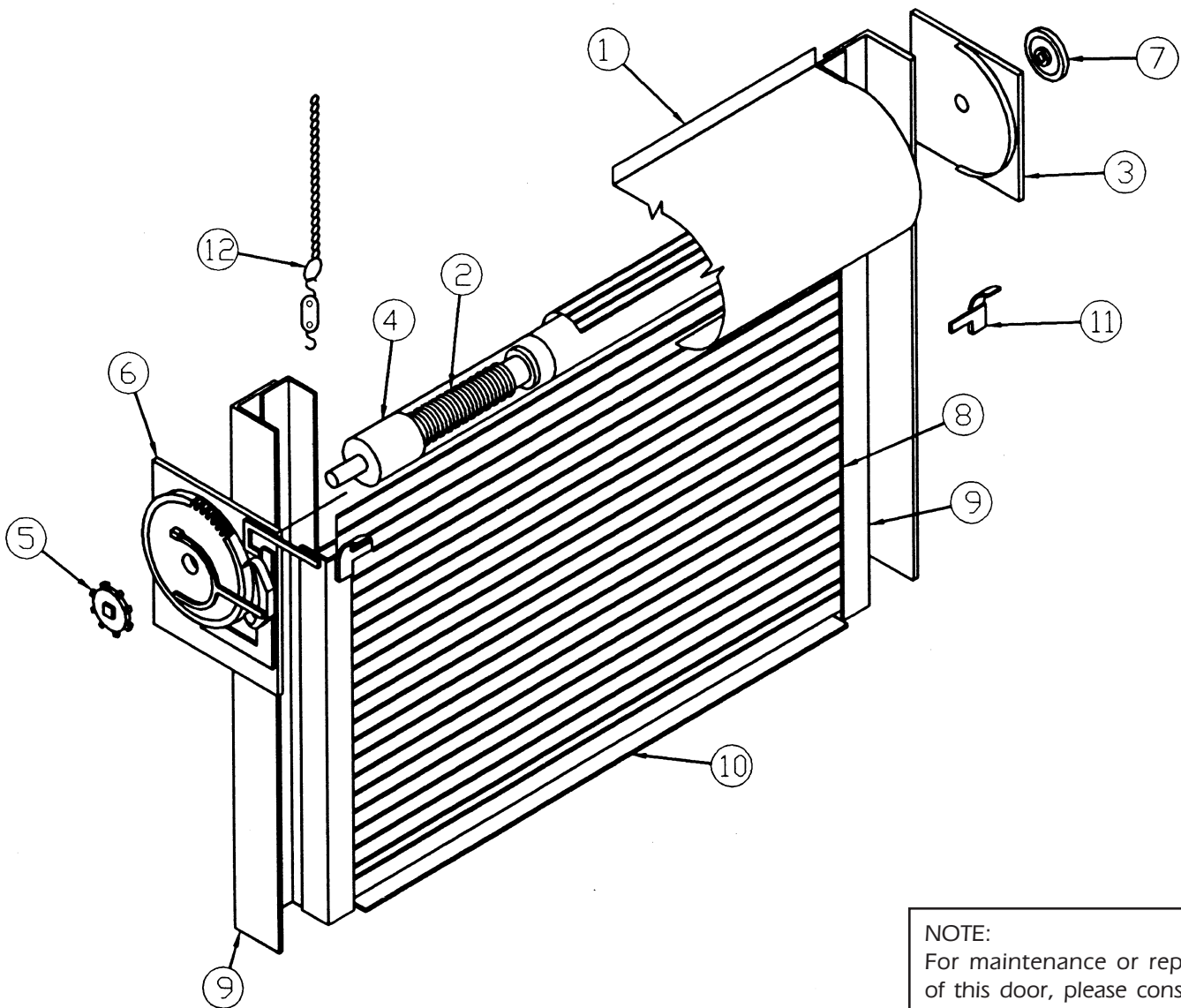

NOTE:

For maintenance or repair of this door, please consult your local authorized Distributor.

**PARTS LIST:
FACE MOUNTED,
MOTOR OPERATED,
FIRE DOOR**

NO.	ITEM
1	Hood
2	Tension Spring
3	Drive Bracket
4	Barrel
5	Tension Bracket
6	Tension Wheel
7	Curtain

NO.	ITEM
8	Guides
9	Bottom Bar
10	Stops
11	Hood Support (if required)
12	Fusible Link Assembly
13	Motor Operator

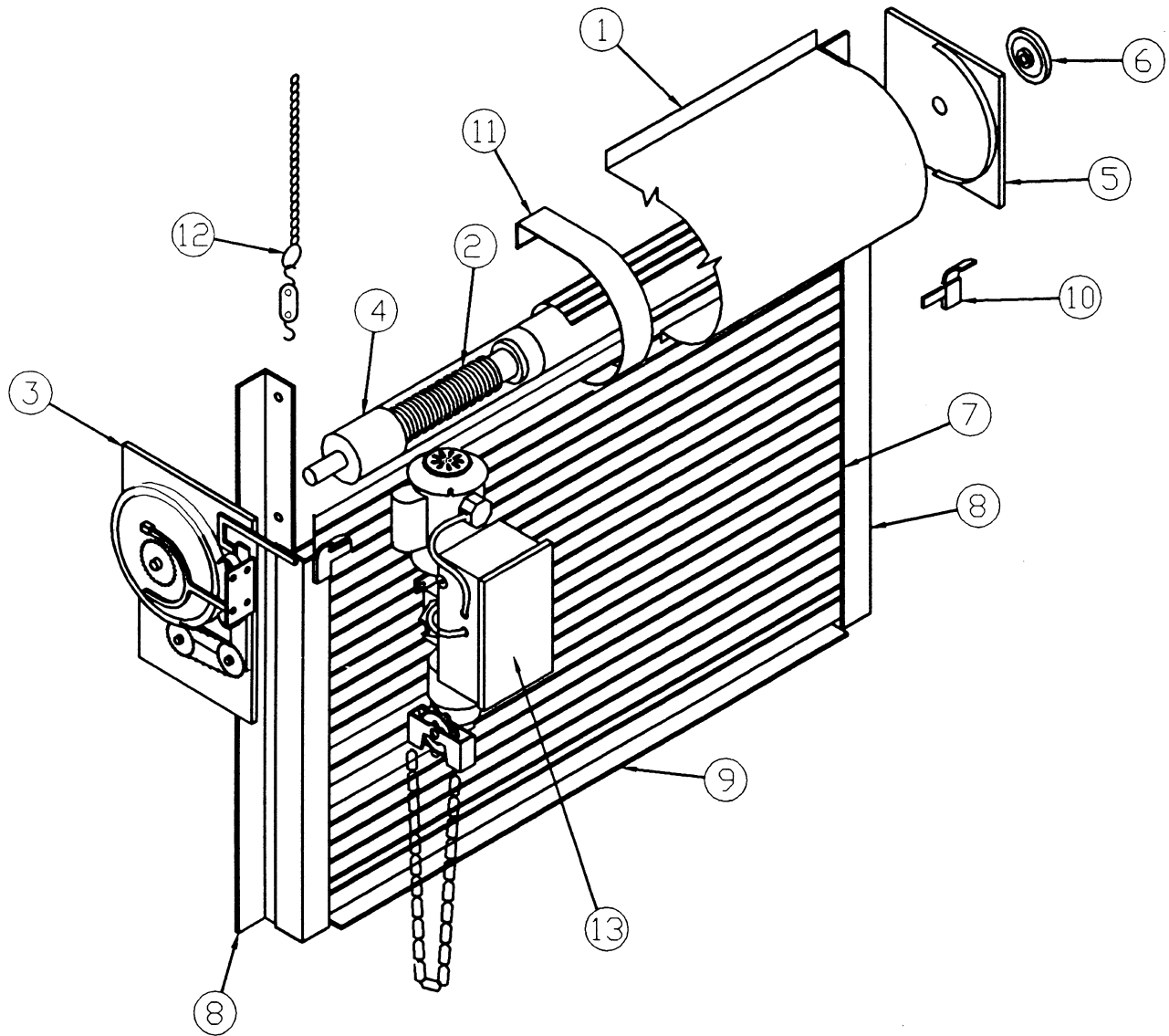

DOOR INSTALLATION

- A. Many problems encountered with rolling fire doors are a result of improper installation of the door. Each door is provided with a set of installation instructions that must be followed to insure proper operation. Installation problems can remain undetected on doors that are seldom operated, therefore it is important to consider incorrect installation as a common cause of problems.
- B. A door must be inspected prior to installation to insure that none of the components have been damaged in shipment. Damaged components should not be used to install a door.
- C. The guides of the door must be plumb and mounted the correct distance apart along their entire length. Mounting hardware must not project into the guide because the curtain must be free to move in the guide. The tops of guides must be level to insure that the barrel of the door is level. The use of a Hydro-Level is an accurate method of leveling the guides.
- D. The barrel of the door must be free to turn when supported by the brackets. If hoops are required, they must be installed on the barrel before the curtain and brackets are installed on the barrel. The curtain is attached to the barrel with machine screws that pass through slots in the top slat.
- E. The curtain of the door must pass freely through the guides without binding. The guides must be plumb and mounted to the correct guide opening dimension. The guide groove opening must be adjusted to the dimension shown in the installation instructions.
- F. The torsion spring must be tensioned to the number of initial turns shown in the installation instructions. On large motor operated doors, it may not be possible to raise the door by hand if the initial tension is not applied. When this occurs, the weight of the door must be lifted while the hand operator is used to coil the curtain on the barrel.
- G. The door operator must be free to turn and securely mounted to the bracket. Bracket plates must be perpendicular to the barrel to insure that chains, sprockets, and gears engage properly.
- H. All door components are labeled, stamped, or tagged with corresponding Cookson Door Mark. Parts must not be interchanged for different doors.

NOTE:

For maintenance or repair of this door, please consult your local authorized Distributor.

BARREL

TROUBLESHOOTING GUIDE		
PROBLEM	CAUSE	CORRECTION
A. Door starts down then binds.	<ol style="list-style-type: none">1. Curtain binds in guides.2. Screws connecting curtain to barrel too long and interfering with torsion spring.3. Incorrect barrel for opening.4. Internal interference inside barrel. Dent in wall of barrel.	<ol style="list-style-type: none">1. Increase guide groove opening. Curtain must be loose in guides.2. Replace machine screws with shorter length. They must not protrude past barrel wall.3. Check door mark. Locate correct barrel.4. Consult Distributor.
B. Tension wheel turns freely.	<ol style="list-style-type: none">1. Spring broken.2. Broken shaft tie.3. Broken barrel tie.	<ol style="list-style-type: none">1. Consult Distributor.2. Consult Distributor.3. Consult Distributor.
C. Tension shaft slipped into barrel.	<ol style="list-style-type: none">1. Drive pin failure - shipping damage.2. Bearing failure - shipping damage.	<ol style="list-style-type: none">1. Consult Distributor.2. Consult Distributor.
D. Door loses tension.	<ol style="list-style-type: none">1. Door damaged causing increased drag.	<ol style="list-style-type: none">1. Consult Distributor.
E. Drive shaft crooked.	<ol style="list-style-type: none">1. Broken weld or shipping damage.	<ol style="list-style-type: none">1. Consult Distributor for determination if field repair is possible.

TROUBLESHOOTING GUIDE

PROBLEM	CAUSE	CORRECTION
A. Curtain rolls up un-evenly.	<ol style="list-style-type: none"> 1. Top slat not in line. 2. Barrel not level. 	<ol style="list-style-type: none"> 1. Loosen top screws and straighten curtain. 2. Use Hydro-level to level barrel.
B. Door curtain separates.	<ol style="list-style-type: none"> 1. Freight damage. 	<ol style="list-style-type: none"> 1. Replace curtain.
C. Curtain separates from barrel.	<ol style="list-style-type: none"> 1. Machine screws pulled through top slat. 2. Interlocks not installed on motor operated door. 	<ol style="list-style-type: none"> 1. Install washer under head of screws. 2. Install interlocks to prevent motor operation when door is locked.
D. Finish problems.	<ol style="list-style-type: none"> 1. Stainless steel door corrodes due to environmental conditions. 	<ol style="list-style-type: none"> 1. Clean door periodically with stainless steel wool and rinse with clean water.
E. Curtain appears to sag at center.	<ol style="list-style-type: none"> 1. Center of curtain is against barrel and edge of curtain is pulled toward lintel as it enters guides. 2. Barrel deflection of wide doors. Should not exceed .03 inches per foot of opening width. 	<ol style="list-style-type: none"> 1. Curvature of curtain makes it appear to be sagging while it is actually level. Check with carpenter's level. 2. Consult Distributor.

NOTE:
 For maintenance or repair of this door, please consult your local authorized Distributor.

BOTTOM BAR

TROUBLESHOOTING GUIDE		
PROBLEM	CAUSE	CORRECTION
A. Safety Edge not working.	1. Open circuit in bottom bar. Confirm this by disconnecting plug at bottom bar and inserting continuity checker. If pressing up on safety edge does not close circuit, problem is open circuit in bottom bar.	1. Defective switch or connection at switch to plug. Check to make sure all wires are securely fastened. Replace switch if necessary.
	2. Open circuit in coil cord or cord reel. Confirm this by inserting volt-meter into plug. Reading should be 24V AC.	2. Replace coil cord or cord reel.
	3. Door located in extremely wet or flood environment.	3. Eliminate water. Replace safety edge or safety edge switch.
B. Locks inoperative.	1. Cam of cylinder not in correct position.	1. Reposition cylinder and firmly secure with small screw located below cylinder.
	2. Damage to internal components.	2. Remove bottom bar from guide. Replace lock mechanism.
D. Electrical interlocks inoperative.	1. Lock bolt does not line up with switch on guide.	1. Adjust switch location where it is mounted on guides.
	2. Interlock does not prevent motor from operating.	2. Defective switch, check electrical connection and replace if necessary.

BRACKET

TROUBLESHOOTING GUIDE		
PROBLEM	CAUSE	CORRECTION
A. Brackets not perpendicular to barrel.	1. Wall angle flange not square.	1. Brace bracket into position.
B. Drive chain tension.	1. Sprocket position out of adjustment.	1. Tighten chain by sliding operator or remove link from chain.
C. Binding in bevel gear box.	1. Lack of lubrication.	1. Lubricate gear box.

GUIDE

TROUBLESHOOTING GUIDE		
PROBLEM	CAUSE	CORRECTION
A. Curtain binds in guide groove.	1. Incorrect guide groove opening. 2. Incorrect tip to tip dimension of guides.	1. Refer to installation instructions and adjust guide groove opening. 2. Refer to installation instructions for tip to tip dimension and adjust guide spacing.

HOOD

TROUBLESHOOTING GUIDE		
PROBLEM	CAUSE	CORRECTION
A. Incorrect dimensions, material, or end covers.	1. Ordering processing problem.	1. Get all dimensions of material supplied and consult distributor.

NOTE:
For maintenance or repair of this door, please consult your local authorized Distributor.

**PARTS LIST:
FACE MOUNTED
CHAIN OPERATED
COMPOUND FIRE DOOR
BRACKET**

NO.	ITEM
1	Bracket Plate
2	Chain Operator
3	Cradle Arm Assembly
4	Pallet
5	Release Arm Assembly
6	Main Sprocket
7	Scape Wheel Assembly
8	Drive Sprocket w/ Pinion
9	Fusible Link Assembly

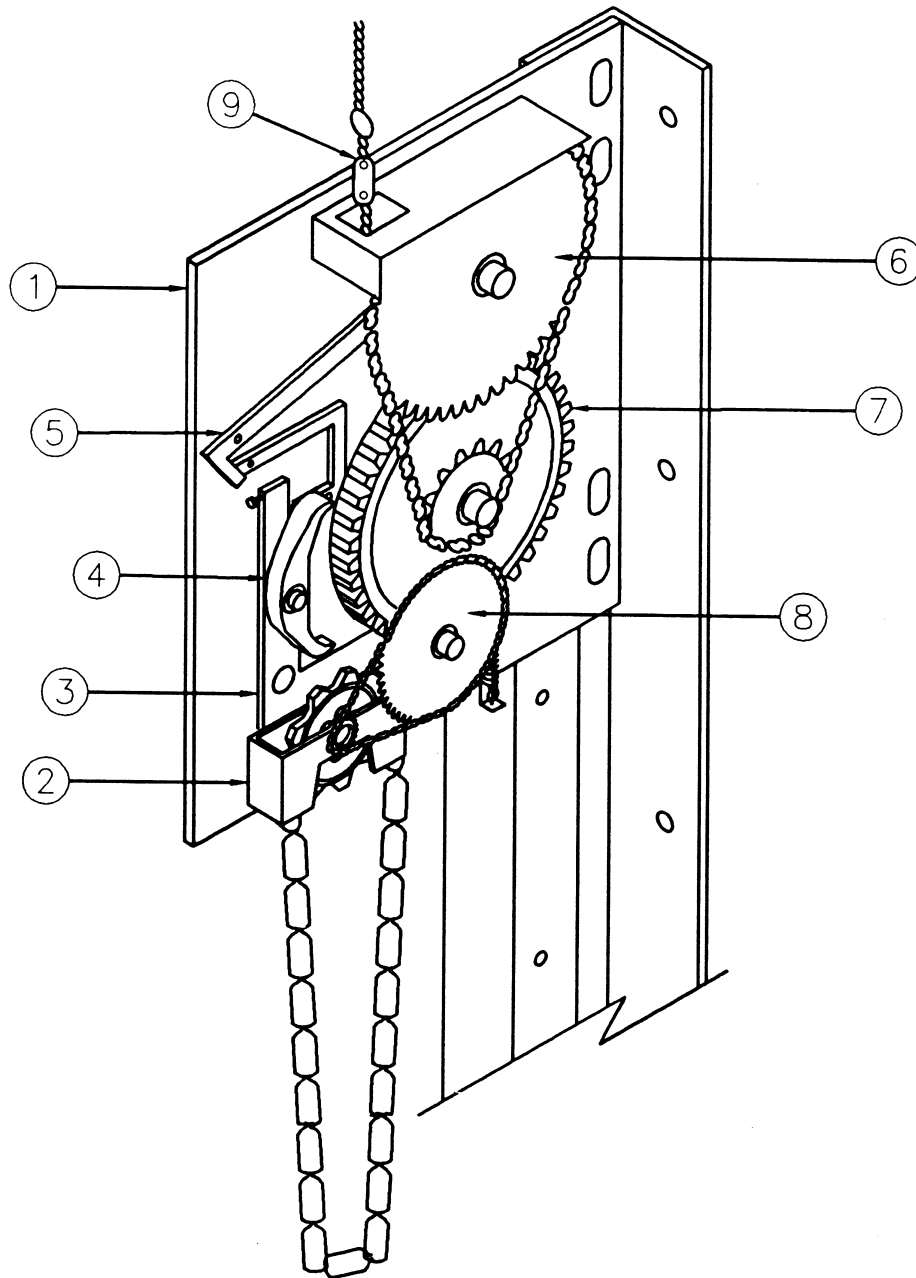

NO.	ITEM
1	Cradle Arm Assembly
2	Motor Operator
3	Drive Sprocket
4	Pallet
5	Manual Operator
6	Bracket Plate
7	Double Int. Sprockets
8	Pinion Gear w/ Sprocket
9	Scape Wheel
10	Release Arm
11	Fusible Link Assembly

**PARTS LIST:
VERTICAL MOUNTED
MOTOR FIRE DOOR
BRACKET**

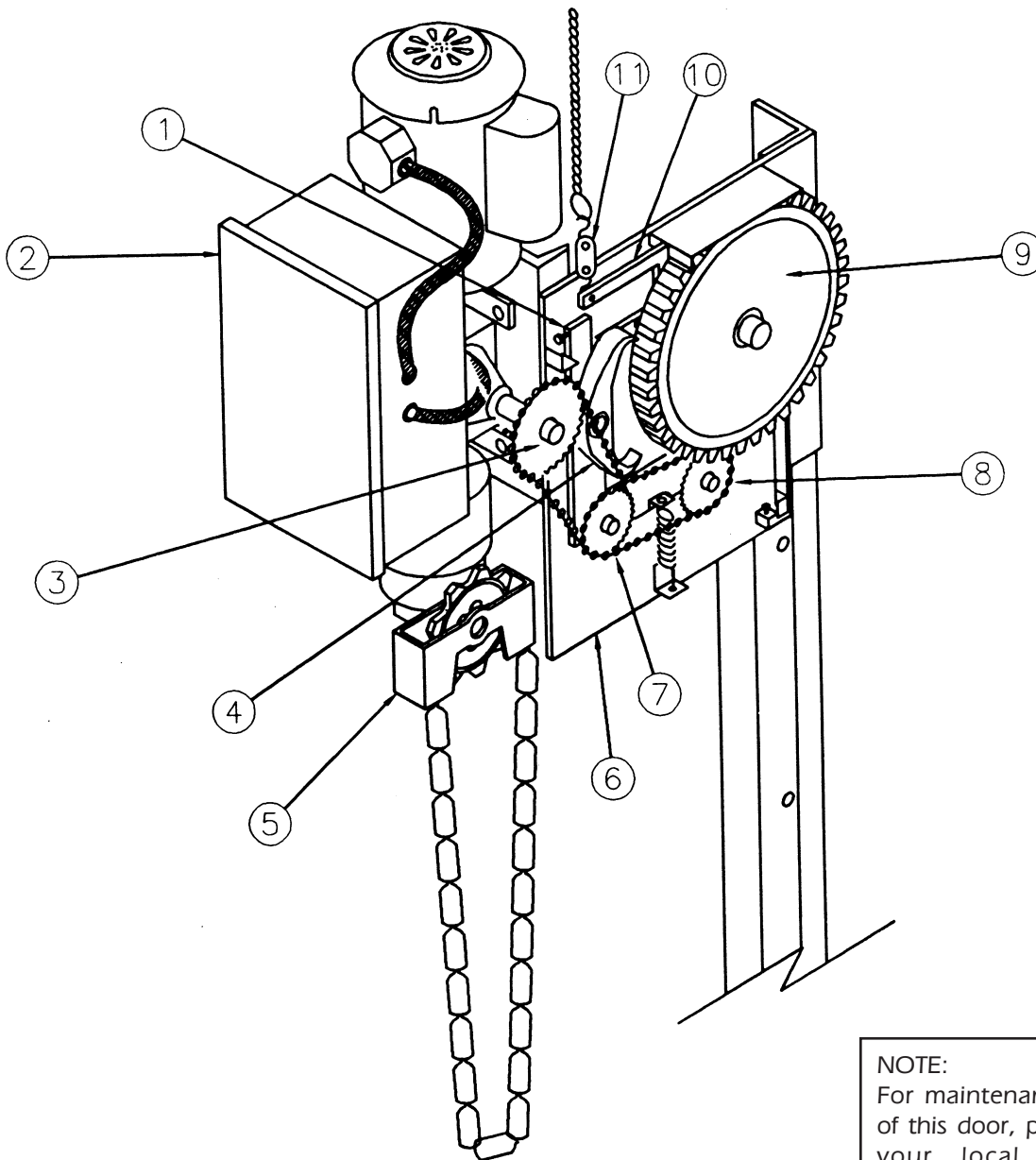

NOTE:
For maintenance or repair
of this door, please consult
your local authorized
Distributor.

**PARTS LIST:
HORIZONTAL
MOUNTED MOTOR
FIRE DOOR
BRACKET**

NO.	ITEM
1	Motor Operator
2	Manual Operator
3	Drive Sprocket
4	Pallet
5	Double Int. Sprockets
6	Pinion Gear w/ Sprocket
7	Scape Wheel
8	Bracket Plate
9	Release Arm
10	Cradle Arm Assembly
11	Fusible Link Assembly

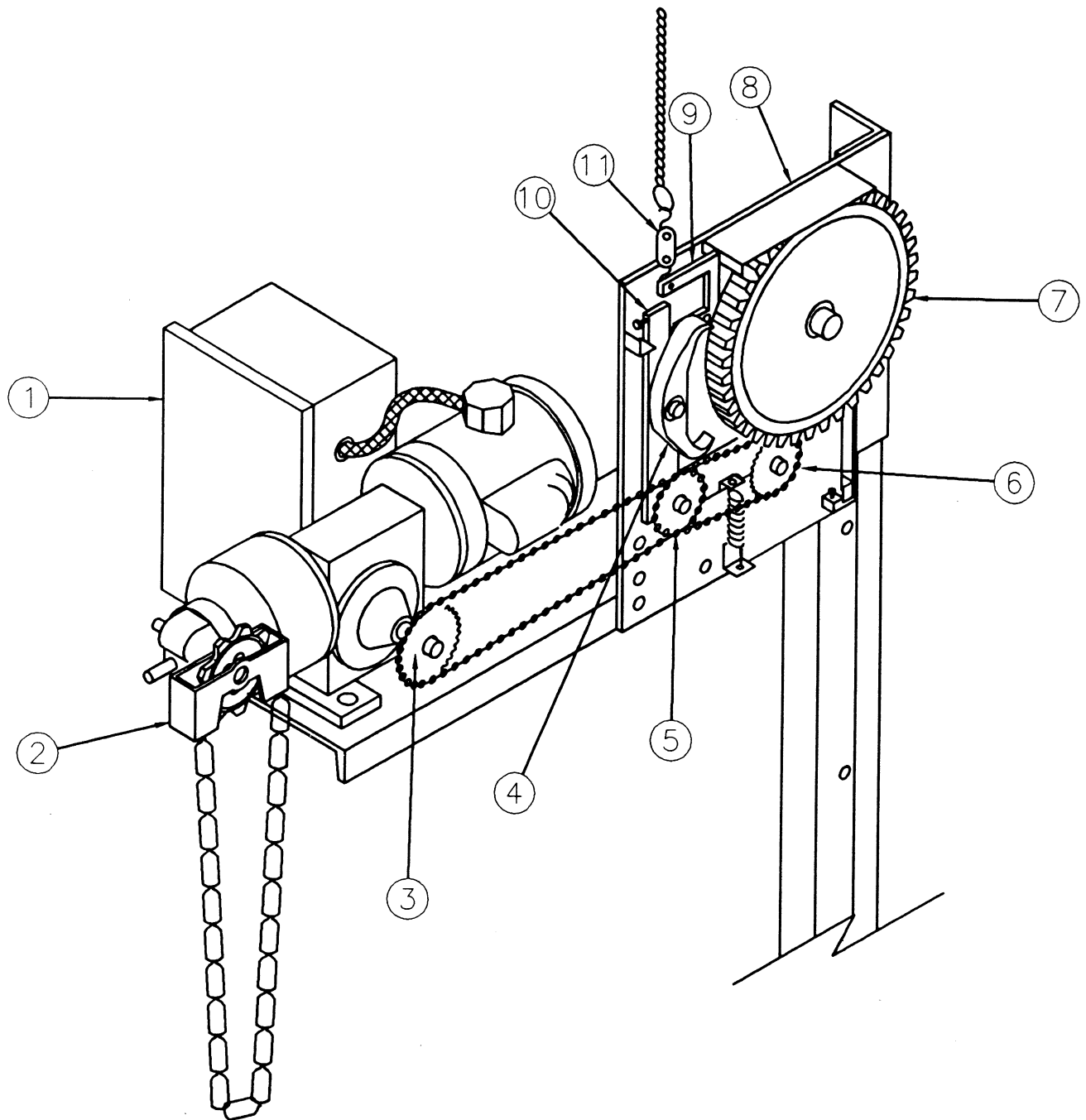

**PARTS LIST:
SIDE MOUNTED
MOTOR FIRE DOOR
BRACKET**

NO.	ITEM
1	Cradle Arm Assembly
2	Pinion Gear w/ Sprocket
3	Pallet
4	Double Int. Sprockets
5	Bracket Plate
6	Motor Operator
7	Manual Operator
8	Scape Wheel
9	Release Arm
10	Fusible Link Assembly

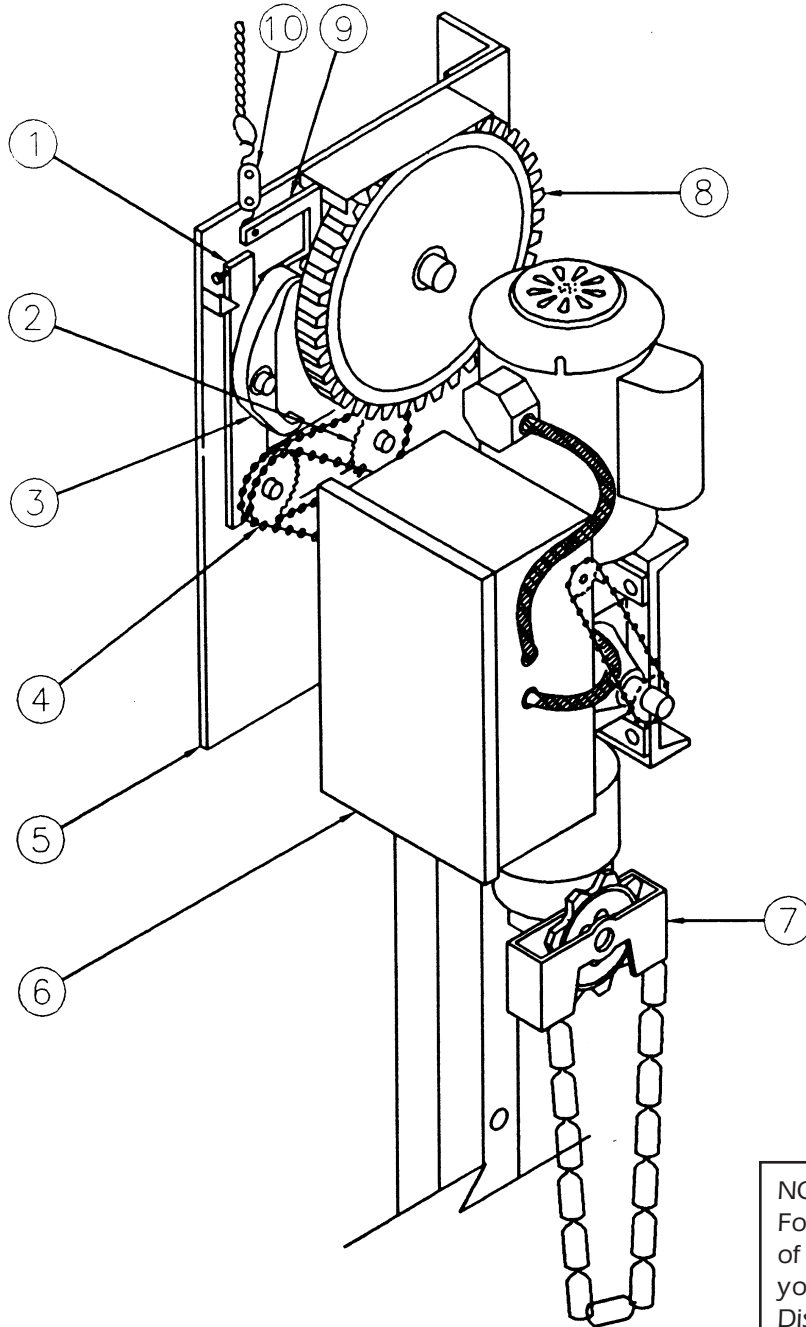

NOTE:
For maintenance or repair
of this door, please consult
your local authorized
Distributor.

MOTOR OPERATOR

TROUBLESHOOTING GUIDE		
PROBLEM	CAUSE	CORRECTION
A. Emergency hand chain or crank fails or is difficult to operate door.	<ol style="list-style-type: none"> 1. Door may be jammed or obstructed. 2. Incorrect tension in spring. 3. Door may be locked. 4. Problem in gearbox housing. 	<ol style="list-style-type: none"> 1. Remove Obstruction. 2. Make sure that spring has correct tension. 3. Check to see if lock is disengaged. 4. Consult Distributor.
B. Emergency hand chain or crank turns but does not turn the output shaft of gear box.	<ol style="list-style-type: none"> 1. Keys fixing gears to shafts are sheared. 	<ol style="list-style-type: none"> 1. Check keys and keyways.
C. Motor fails to run or control circuit fails to energize.	<ol style="list-style-type: none"> 1. Fuses blown or circuit breaker "tripped". 2. Operators are protected from running in overload condition by thermal overload devices of the automatic reset type. 3. If contacts for motor controller energize but motor still fails to operate. 4. Pushbuttons energize on only one side of the control contacts. 	<ol style="list-style-type: none"> 1. Check fuse or circuit breaker box. 2. Consult Distributor. 3. Consult Distributor. 4. Check all electrical connections for broken or loose wires, etc. Check electrical connections for any optional equipment: Card Key, Cylinder Key Switch, Photo Cell, Reversing Bottom Bar or Special Interlocks.
D. Movement of the door is in agreement with pushbutton station, but the limit switch does not stop the door.	<ol style="list-style-type: none"> 1. Electrical connections are switched. 	<ol style="list-style-type: none"> 1. Check electrical connections and jumper wire lead between the micro switches. Consult Distributor.
E. Limit Switch does not hold its setting.	<ol style="list-style-type: none"> 1. Sprocket shaft end play too large. 2. Drive chain loose. 3. Limit switch detent plate loose. 	<ol style="list-style-type: none"> 1. End play should not exceed $\frac{1}{32}$". 2. Check drive chain. 3. The plate must engage both traveling cams.

**MOTOR OPERATOR
(continued)**

TROUBLESHOOTING GUIDE		
PROBLEM	CAUSE	CORRECTION
F. Electrical Control Circuit energizes but the motor does not run or motor overloads trip.	1. Incorrect wiring.	1. Consult Distributor.
G. Low voltage to motor.	1. Incorrect electrical power to motor.	1. Check voltage against the correct voltage stamped on the motor. If the voltage is 10% below the rating, there is not sufficient voltage to run the motor.
H. Motor is burned out.	1. Incorrect wiring.	1. Consult Distributor.

NOTE:
For maintenance or repair of this door, please consult your local authorized Distributor.

**PARTS LIST:
MODEL GH MOTOR**

NO.	ITEM
1	Motor
2	Limit Switch Main Sprocket
3	Control Panel
4	Drive Sprocket
5	Miter Gear
6	Release Linkage
7	Chain Sprocket

NO.	ITEM
8	Chain Guard
9	Gear Box
10	Manual Operator Lever
11	Roller Chain
12	Limit Switch Drive Sprocket
13	Reducer

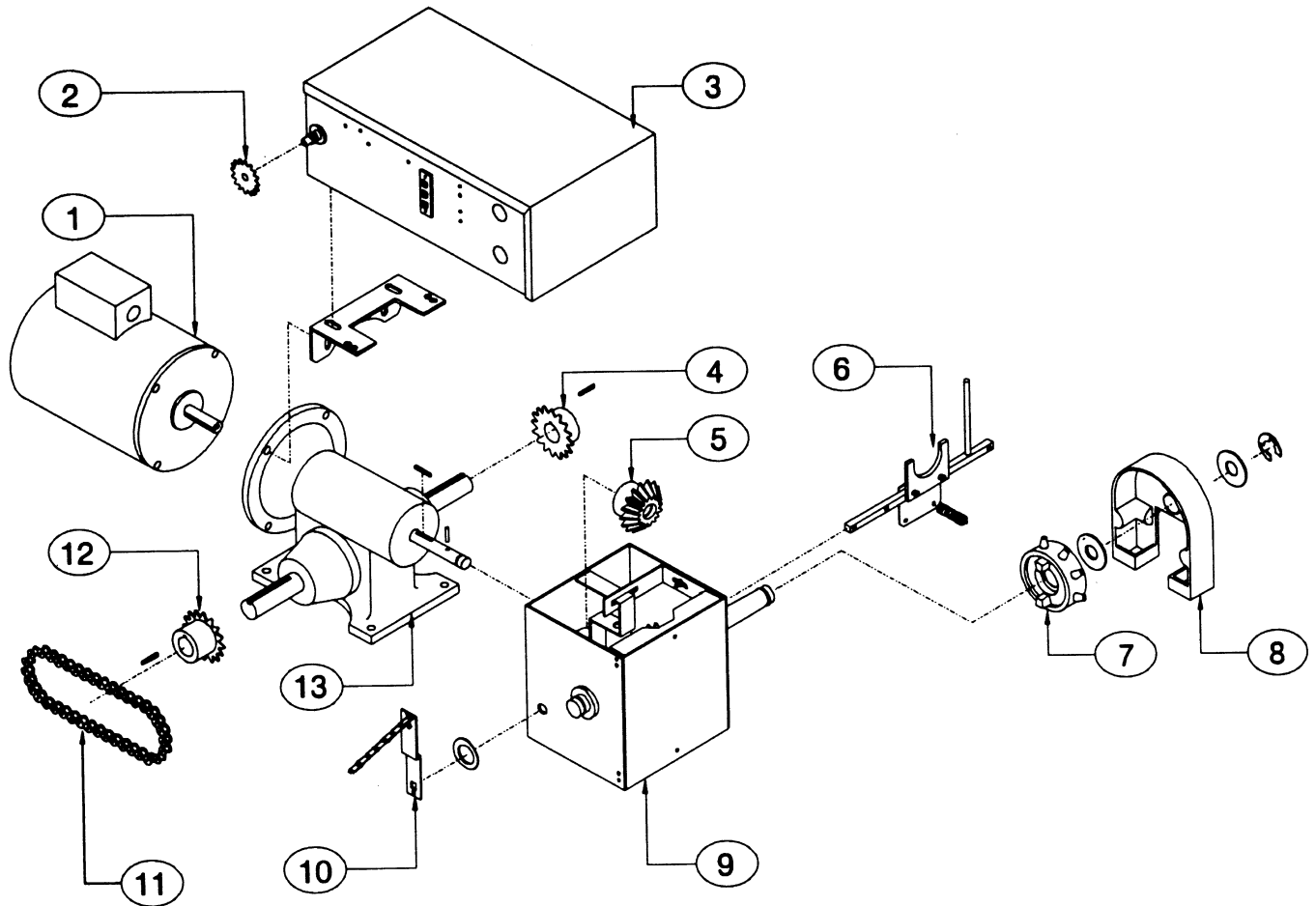

NO.	ITEM
1	Control Panel
2	Limit Switch Main Sprocket
3	Roller Chain
4	Limit Switch Drive Sprocket
5	Release Linkage
6	Chain Guard
7	Chain Sprocket

NO.	ITEM
8	Manual Operator Lever
9	Motor
10	Gear Box Enclosure
11	Drive Pulley
12	Main Pulley
13	Drive Belt
14	Drive Spocket

**PARTS LIST:
MODEL MH MOTOR**

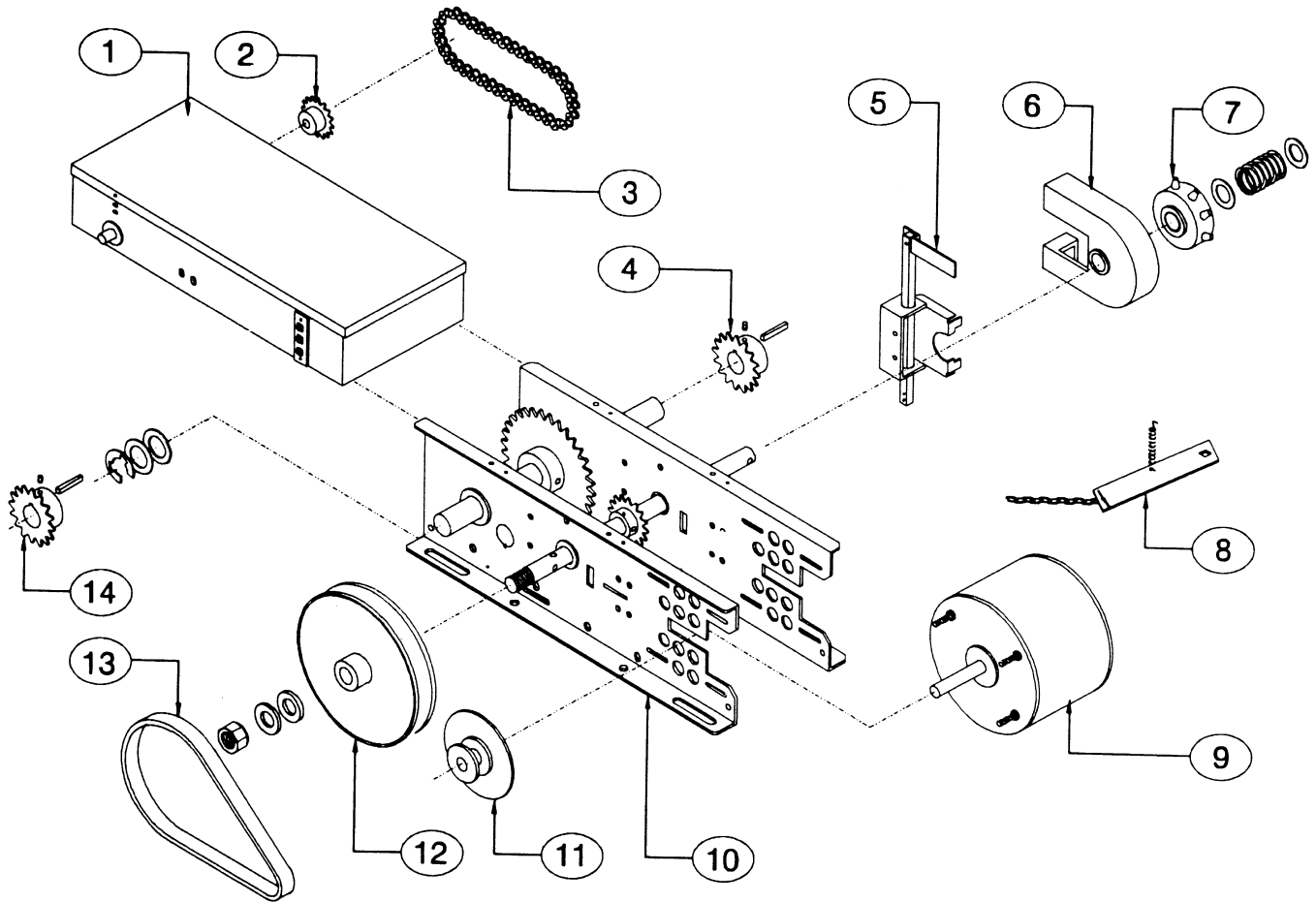

NOTE:
For maintenance or repair of this door, please consult your local authorized Distributor.

**PARTS LIST:
MODEL H MOTOR**

NO.	ITEM
1	Manual Operator Lever
2	Limit Switch Drive Sprocket
3	Gear Box Enclosure
4	Drive Sprocket
5	Main Pulley
6	Control Panel
7	Drive Belt

NO.	ITEM
8	Drive Pulley
9	Motor
10	Limit Switch Main Sprocket
11	Roller Chain
12	Release Linkage
13	Chain Guard
14	Chain Sprocket

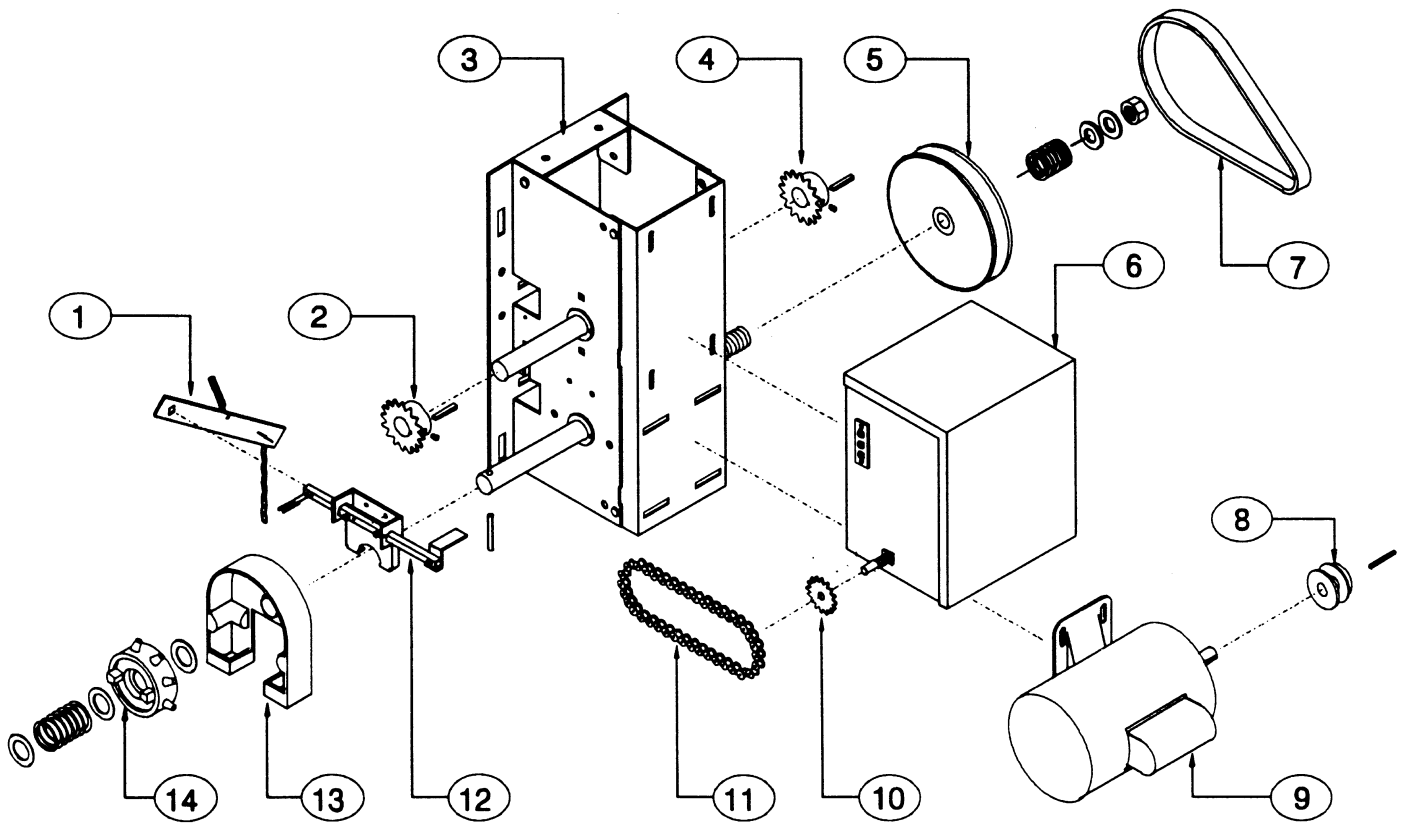

**PARTS LIST:
MODEL GJ MOTOR**

NO.	ITEM
1	Reducer
2	Motor
3	Motor Mounting Bracket
4	Release Cam
5	Drive Spocket
6	Release Linkage
7	Manual Operator Lever
8	Roller Chain
9	Control Panel
10	Limit Switch Drive Sprocket

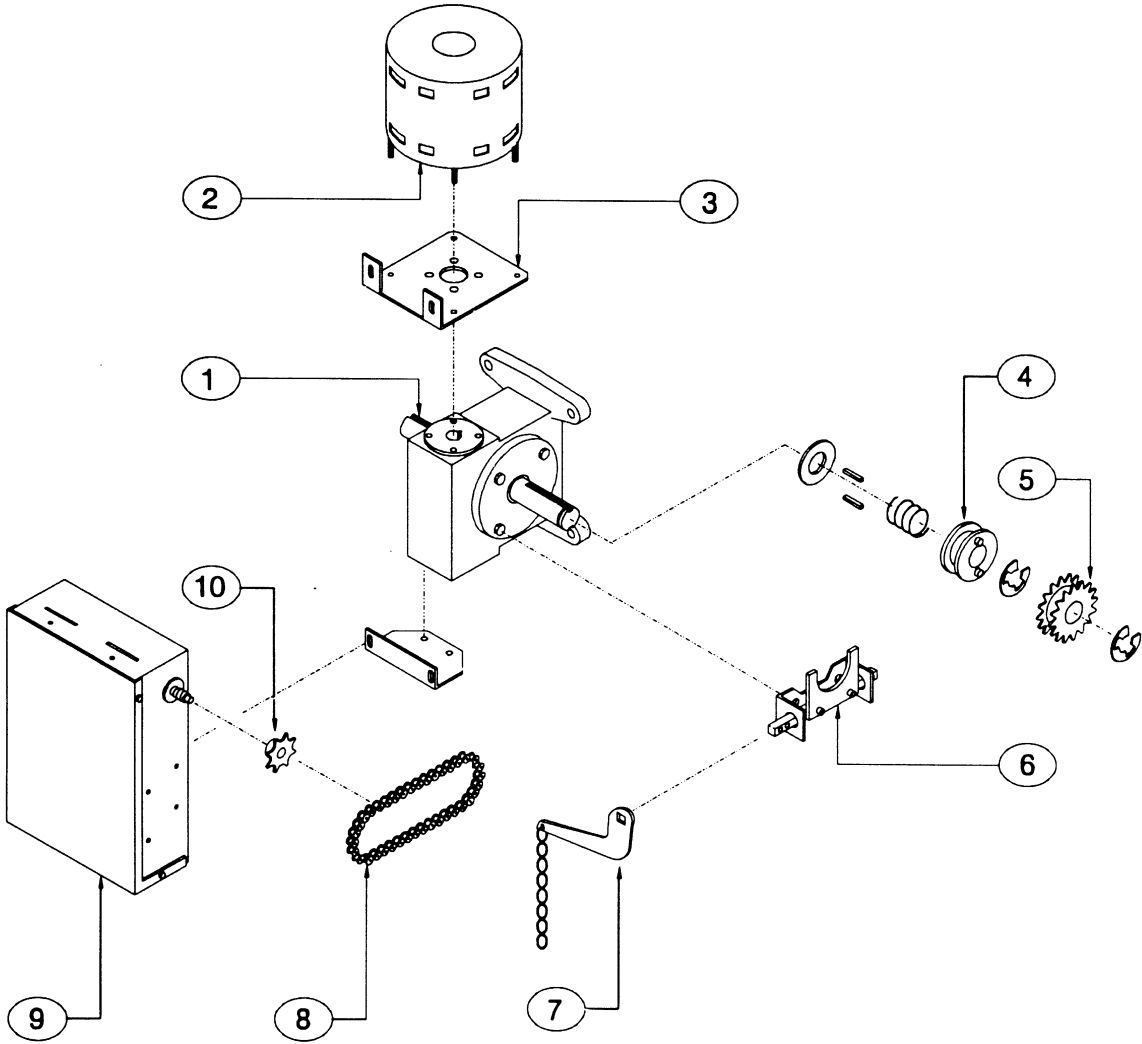

NOTE:
For maintenance or repair of this door, please consult your local authorized Distributor.

MAINTENANCE INSTRUCTIONS

**CAUTION:
ONLY TRAINED PERSONNEL SHOULD PERFORM MAINTENANCE.**

1. INSPECT FOR CONFORMANCE TO NFPA 80:
 - a. Installation
 - b. Fuse Links
 - c. Mounting

2. INSPECT CONDITION OF:
 - a. Curtain
 - b. Bottom Bar
 - c. Hood
 - d. Bracket
 - e. Guide
 - f. Barrel
 - g. Operating Assembly
 - h. Governor Assembly
 - i. Fuse Links
 - j. Release Holders
 - k. Smoke Detectors
 - l. Raceways
 - m. Cabling

3. LUBRICATE:
 - a. All Pivot Joints
 - b. Shafts
 - c. Roller Chain

4. CHECK NORMAL OPERATION:
 - a. Operation
 - b. Spring Tension
 - c. Balance

5. TEST DROP

6. CAUTION: ONLY TRAINED PERSONNEL SHOULD TEST AND RESET FIRE DOORS.
 - a. Reset per Manufacturer's Instructions only.