

Safedrive DOOR OPERATORS

Assured Quality

All Safedrive® operators are manufactured to quality standard DIN EN ISO 9001, ensuring trouble free installation and operation.

Integrated Anti-Backdrive

Provides safety for failure of reducer and operates independent of speed or direction. It is maintenance free, self-monitoring, and has excellent dampening characteristics for smooth and quiet door operation.

Versatile Applications

Safedrive® is suitable for balanced and unbalanced sectional doors, rolling steel doors, rolling grilles, and hi-speed fabric doors. Mounting is either bracket or wall mount depending on the application.

High Speed

Capable of trouble free operating speeds of up to 100"/sec when used in hi-speed door applications.

Digital Controls

Easy to set and adjust digital limits making installation and door maintenance a breeze. Door limits are set using the Safedrive® Digital Control Panel. Plug and play numbered wires makes electrical wiring simple. Re-adjustment is not required after a power failure. The system is CUL approved.

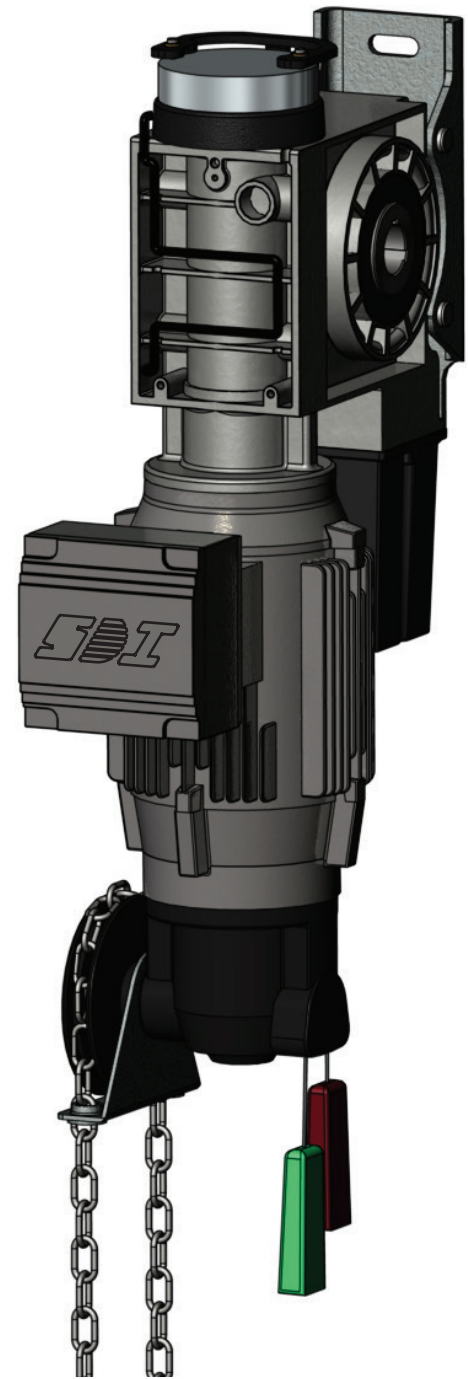

Safedrive® Digital Control Panel

Safedrive OPERATOR DETAILS

ROLLING STEEL

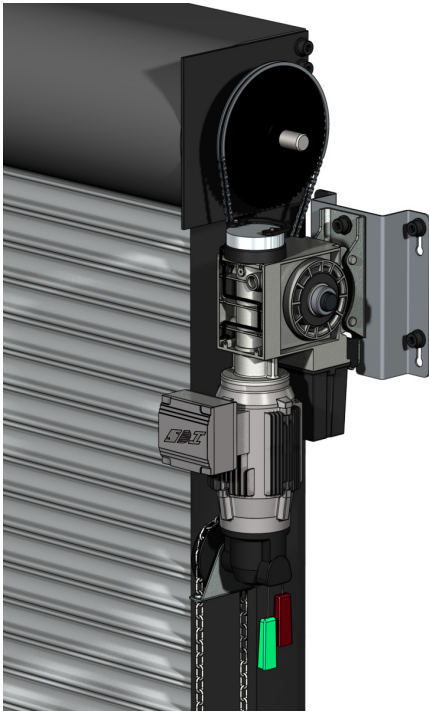

HI-SPEED FABRIC

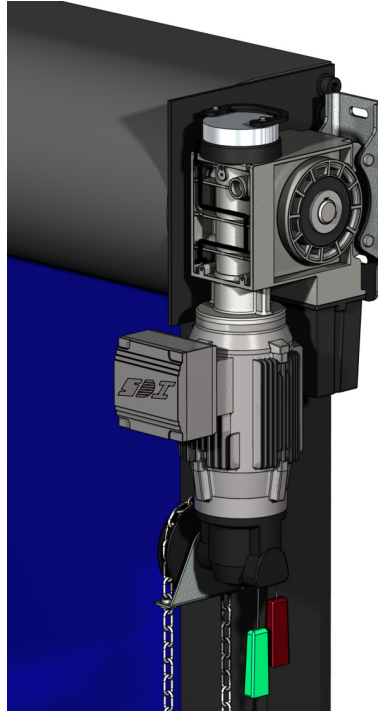

SECTIONAL

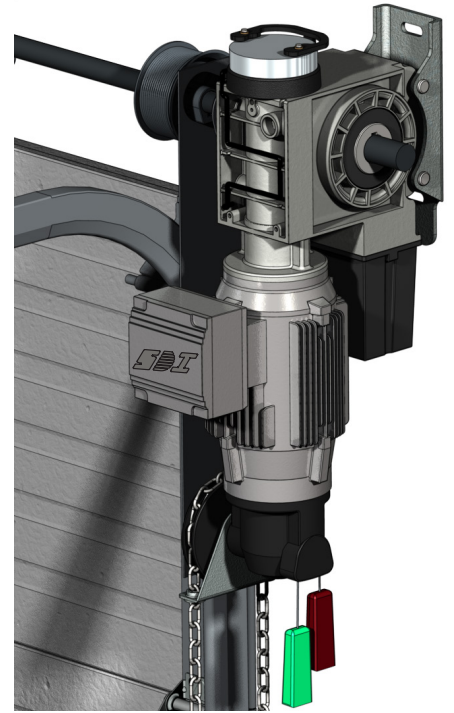

Safedrive® DIMENSIONS

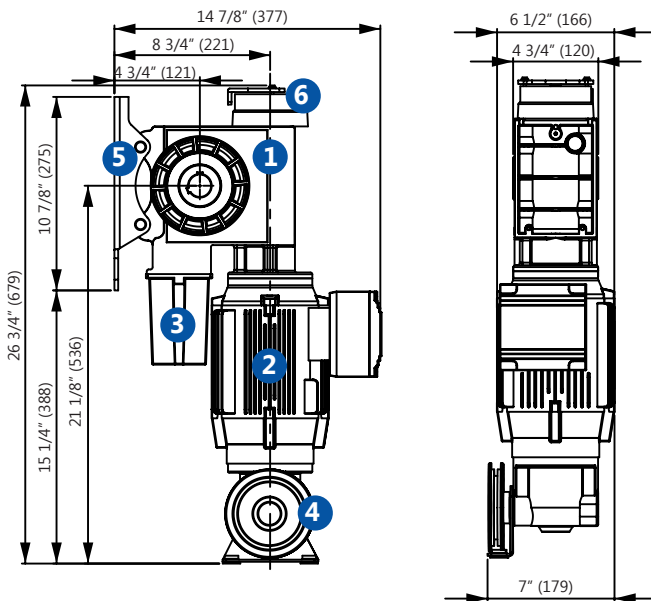

- 1 Worm gear with safety break
- 2 Motor
- 3 Limit assembly
- 4 Chain hoist
- 5 Floating foot
- 6 Electric brake

FEATURES

- Direct drive mechanicals or with chain adapter.
- Anti-backdrive reducer.
- Limits set at ground level.
- Pre-wired control panel with easy setup instructions.
- Power supply: 230V 1PH or 230V/460V/575V 3PH.
- Sophisticated controls to meet the demands of any application.
- Built-in cycle counter.
- Status indication screen on control panel
- Auxiliary crank operation available.