

**GENERAL NOTES:**

1. ROLL-UP DOOR SHOWN ON THIS PRODUCT APPROVAL DOCUMENT (P.E.D.) HAS BEEN VERIFIED FOR COMPLIANCE IN ACCORDANCE WITH THE 2017 (6th EDITION) OF THE FLORIDA BUILDING CODE.  
 DESIGN WIND LOADS SHALL BE DETERMINED AS PER SECTION 1620 OF THE ABOVE MENTIONED CODE, FOR A BASIC WIND SPEED AS REQUIRED BY THE JURISDICTION WHERE THESE SHUTTERS WILL BE INSTALLED FOR A DIRECTIONALITY FACTOR  $K_d=0.85$ . USING ASCE 7-10 FOR INSTALLATIONS UNDER 2017 FBC AND SHALL NOT EXCEED THE MAXIMUM (A.S.D.) DESIGN PRESSURE RATINGS INDICATED ON SHEET 6.  
 IN ORDER TO VERIFY THE ABOVE CONDITION, ULTIMATE DESIGN WIND LOADS DETERMINED PER ASCE 7-10 SHALL BE FIRST REDUCED TO A.S.D. DESIGN WIND LOADS BY MULTIPLYING THEM BY 0.6 IN ORDER TO COMPARE THESE W/ MAX. (A.S.D.) DESIGN PRESSURE RATINGS INDICATED ON SHEET 6.  
 IN ORDER TO VERIFY THAT COMPONENTS AND ANCHORS ON THIS P.E.D. AS TESTED WERE NOT OVER STRESSED, A 33% INCREASE IN ALLOWABLE STRESS FOR WIND LOADS WAS NOT USED IN THEIR ANALYSIS. A DURATION FACTOR  $CD=1.60$  WAS USED FOR VERIFICATION OF FASTENERS IN WOOD. ROLL-UP DOOR'S ADEQUACY FOR IMPACT AND FATIGUE RESISTANCE HAS BEEN VERIFIED IN ACCORDANCE WITH SECTION 1626 OF THE ABOVE MENTIONED CODE AS PER ARCHITECTURAL TESTING, INC. REPORTS # 66443.01-109-18 & 78796.01-109-18, PER TAS-201, TAS-202 & TAS-203 PROTOCOLS. THIS PRODUCT IS MANUFACTURED AND ERECTED TO EASILY ENCLOSE AN AREA, PROVIDING PROTECTION FROM HURRICANE FORCE WINDS WITHIN THE LIMITATIONS INCLUDED IN THIS P.E.D.
2. ALL ALUMINUM EXTRUSIONS SHALL BE MADE OF ALLOYS AND TEMPERS, AS INDICATED ON SHEET 2 OF THIS DRAWING.
3. EVERY OTHER SLAT (INCLUDING BASE SLAT) SHALL INCLUDE ONE RETAIN SCREW (C), AISI 304 SERIES STAINLESS STEEL (SEE SHEET 2).
4. ALL SCREWS (EXCEPT COMPONENT # (C)) TO BE STAINLESS STEEL 304 OR 316 AISI SERIES OR ITW BUILDDEX CORROSION RESISTANT COATED CARBON STEEL TEK SCREWS, AS PER DIN 50018 & SHALL COMPLY W/ FLORIDA BUILDING CODE SECTION 2411.3.3.4.
5. BOLTS TO BE ASTM A-307 GALVANIZED STEEL OR AISI 304 SERIES STAINLESS STEEL, WITH 35 ksi MINIMUM YIELD STRENGTH.
6. ANCHORS TO WALL FOR SIDE RAILS CONNECTION SHALL BE AS FOLLOWS:
  - (A) TO EXISTING POURED CONCRETE (MIN.  $f'_c = 2899$  psi) OR GROUT FILLED CELL ASTM C-90 CONCRETE BLOCK:
    - $5/16"$  TAPCON XL ANCHORS, AS MANUFACTURED BY ITW/BUILDDEX, INC.
  - NOTES:
    - A.1) MINIMUM EMBEDMENT OF ANCHORS INTO POURED CONCRETE OR GROUT FILLED CELL CONCRETE BLOCK IS  $2\ 1/4"$ . NO EMBEDMENT INTO STUCCO SHALL BE CONSIDERED AS PART OF THE REQUIRED EMBEDMENT.
    - A.2) IN CASE THAT PRECAST STONE, PRECAST CONCRETE OR BRICK PANELS, VENEER OR PAVERS BE FOUND ON THE EXISTING WALL ANCHORS SHALL BE LONG ENOUGH TO REACH THE MAIN SUBSTRATE BEHIND SUCH PANELS. MINIMUM EMBEDMENT SHALL BE AS INDICATED ON NOTE A.1 ABOVE.
  - (B) TO EXISTING WOOD FRAME WALL: MIN. SPECIFIC GRAVITY  $G = 0.46$  OR  $G = 0.55$  (SEE SCHEDULE)
    - $1/4"$  N.D.S. WOOD SCREWS.
  - NOTES:
    - B.1) MINIMUM THREADED PENETRATION OF ANCHORS INTO WOOD STUDS SHALL BE 3".
    - B.2) ANCHORAGE SHALL BE PERFORMED BEYOND ANY FINISH MATERIAL AT WALL LIKE BRICK VENEER, STUCCO OR ANY OTHER FINISH. ANCHORAGE SHALL BE AS INDICATED ON NOTE B.1.
7. IT SHALL BE THE RESPONSIBILITY OF THE CONTRACTOR TO VERIFY THE SOUNDNESS OF THE STRUCTURE WHERE DOOR IS TO BE ATTACHED TO INSURE PROPER ANCHORAGE. THIS DOOR SHALL ONLY BE ATTACHED TO POURED CONCRETE, GROUT FILLED CELL CONCRETE BLOCK, AND WOOD FRAME BUILDINGS.
8. IT SHALL BE THE RESPONSIBILITY OF THE CONTRACTOR TO VERIFY THAT THE EXISTING STRUCTURE IS DESIGNED TO SUPPORT  $V_x$  AND  $V_y$  FORCES AT BOTH JAMBS. SEE SHEET 6 OF FOR  $V_x$  &  $V_y$  VALUES.
9. THE INSTALLATION CONTRACTOR IS TO SEAL/CAULK ALL DOOR COMPONENT EDGES WHICH REMAIN IN CONTINUOUS CONTACT WITH THE BUILDING TO PREVENT WIND/RAIN INTRUSION.
10. ROLL-UP MECHANISM NOT PART OF THIS APPROVAL, BUT SHALL BE CERTIFIED BY AN INDEPENDENT TESTING AGENCY.
11. ROLL-UP DOOR INSTALLATION SHALL COMPLY WITH SPECS INDICATED IN THIS DRAWING PLUS ANY BUILDING AND ZONING REGULATIONS PROVIDED BY THE JURISDICTION WHERE PERMIT IS APPLIED TO.
12. (a) THIS P.E.D. PREPARED BY THIS ENGINEER IS GENERIC AND DOES NOT PROVIDE INFORMATION FOR A SITE SPECIFIC PROJECT; i.e. WHERE THE SITE CONDITIONS DEVIATE FROM THE P.E.D.  
 (b) CONTRACTOR TO BE RESPONSIBLE FOR THE SELECTION, PURCHASE AND INSTALLATION INCLUDING LIFE SAFETY OF THIS PRODUCT, BASED ON THIS P.E.D. PROVIDED HE/SHE DOES NOT DEVIATE FROM THE CONDITIONS DETAILED ON THIS DOCUMENT. CONSTRUCTION SAFETY AT SITE IS THE CONTRACTOR'S RESPONSIBILITY.  
 (c) THIS P.E.D. WILL BE CONSIDERED INVALID IF ALTERED BY ANY MEANS.  
 (d) SITE SPECIFIC PROJECTS SHALL BE PREPARED BY A FLORIDA REGISTERED ENGINEER OR ARCHITECT WHICH WILL BECOME THE ENGINEER OF RECORD (E.O.R.) FOR THE PROJECT AND WHO WILL BE RESPONSIBLE FOR THE PROPER USE OF THE P.E.D. ENGINEER OF RECORD, ACTING AS A DELEGATED ENGINEER TO THE P.E.D. ENGINEER, SHALL SUBMIT TO THIS LATTER THE SITE SPECIFIC DRAWINGS FOR REVIEW.  
 (e) THIS P.E.D. SHALL BEAR THE DATE AND ORIGINAL SEAL AND SIGNATURE OF THE PROFESSIONAL ENGINEER OF RECORD THAT PREPARED IT.
13. SHUTTER MANUFACTURER'S LABEL SHALL BE LOCATED ON A READILY VISIBLE LOCATION AT DOOR. ONE LABEL SHALL BE PLACED FOR EVERY OPENNING. LABELING TO COMPLY WITH SECTION 1709.5.2.1.1 OF THE FLORIDA BUILDING CODE.

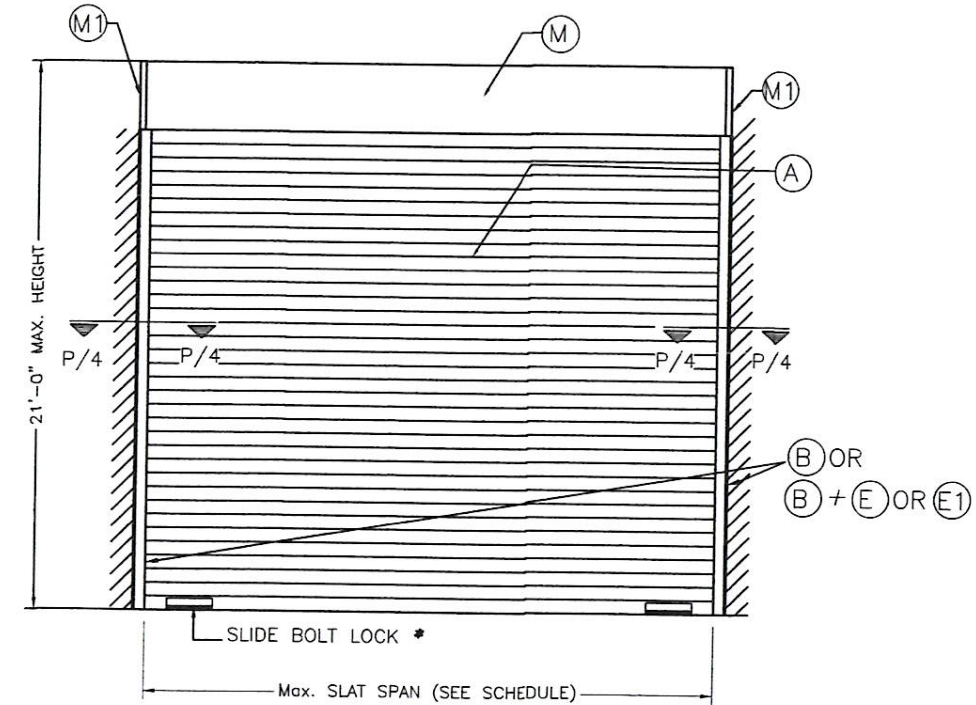

**TYPICAL DOOR ELEVATION (EXTERIOR OR INTERIOR)**

\* Typ. EA. END, INTERIOR, OPTIONAL, ONLY FOR SECURITY PURPOSES.

- NOTES:**
1. SEE SHEETS 2 & 3 FOR COMPONENTS NOMENCLATURE.
  2. SEE SECTIONS ON SHEETS 4 & 5
  3. SEE SCHEDULES ON SHEET 6

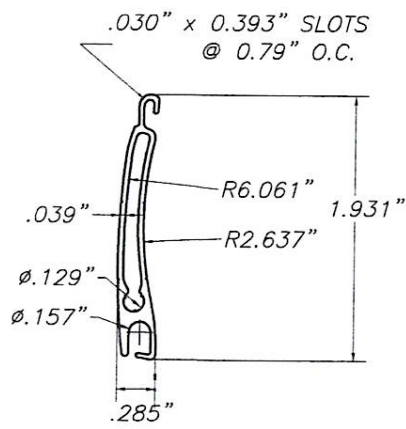

**(A) SLAT**  
6063-T6 ALUMINUM ALLOY  
SCALE: 3/4" = 1"

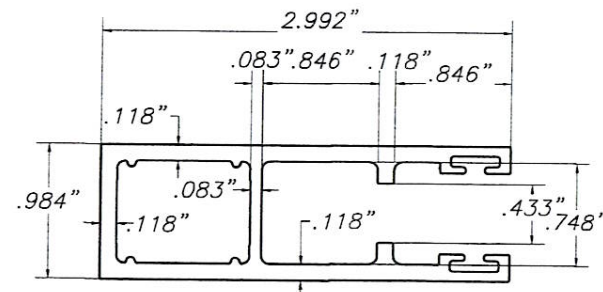

**OPTION #1**

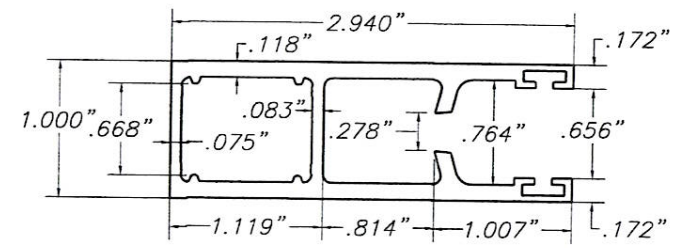

**OPTION #2**

**(B) SIDE RAIL**  
6063-T6 ALUMINUM ALLOY  
SCALE: 3/4" = 1"

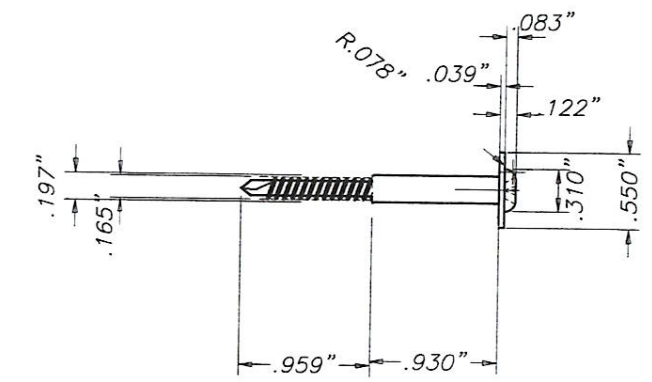

**(C) RETAIN SCREW**  
(1 EVERY OTHER SLAT INCLUDING BASE SLAT  
AND SHALL BE INSTALLED W/A 0.576" MIN. SLIP AS SHOWN ON SECTIONS)  
AISI/SAE 304 SERIES STAINLESS STEEL  
SCALE: 3/4" = 1"

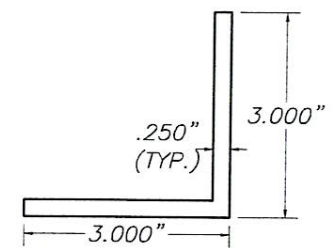

**(E) 3"x3"x1/4" INSIDE MOUNT ANGLE**  
6061-T6 ALUMINUM ALLOY  
SCALE: 3/8" = 1"

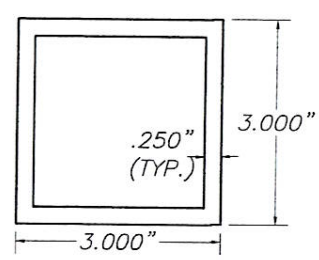

**(E1) 3"x3"x1/4" OPTIONAL INSIDE MOUNT TUBE**  
6061-T6 ALUMINUM ALLOY  
SCALE: 3/8" = 1"

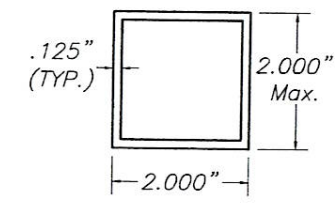

**(G) BUILD-OUT TUBE**  
6061-T6 ALUMINUM ALLOY  
SCALE: 3/8" = 1"

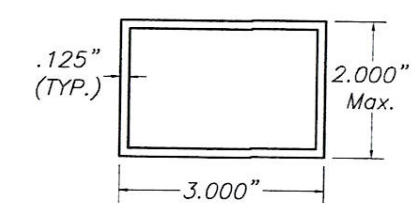

**(G1) ALTERNATE BUILD-OUT TUBE**  
(SEE SHEET 6 FOR REQUIREMENTS TO ANCHORS SPACING)  
6061-T6 ALUMINUM ALLOY  
SCALE: 3/8" = 1"

**COMPONENTS**



TYPE 10 :	N/A
TYPE 9 :	10"
TYPE 8 :	9"
TYPE 7 :	8"
TYPE 6 :	7"
TYPE 5 :	6.5"
TYPE 4 :	6"
TYPE 3 :	5.5"
TYPE 2 :	5"
TYPE 1 :	4"

TYPE 10 :	12"
TYPE 9 :	10"
TYPE 8 :	9"
TYPE 7 :	8"
TYPE 6 :	7"
TYPE 5 :	6.5"
TYPE 4 :	6"
TYPE 3 :	N/A
TYPE 2 :	N/A
TYPE 1 :	N/A

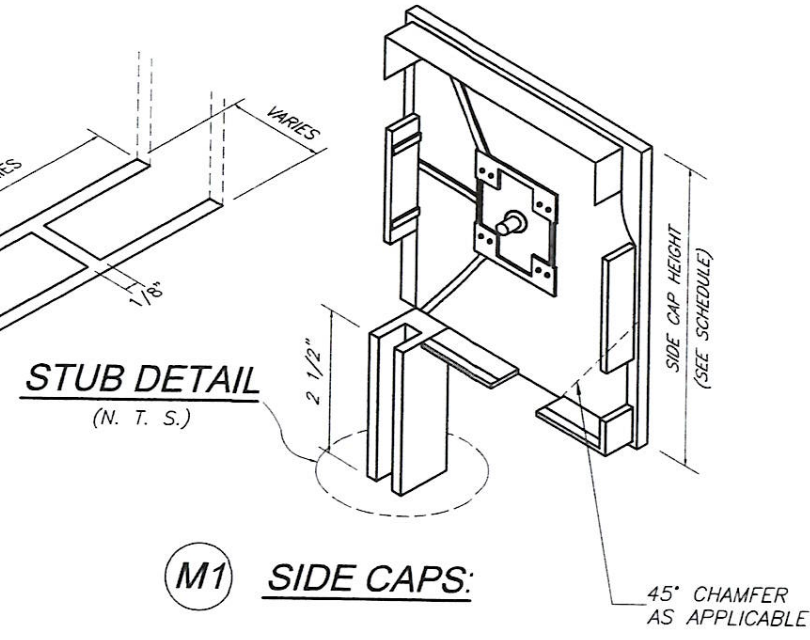
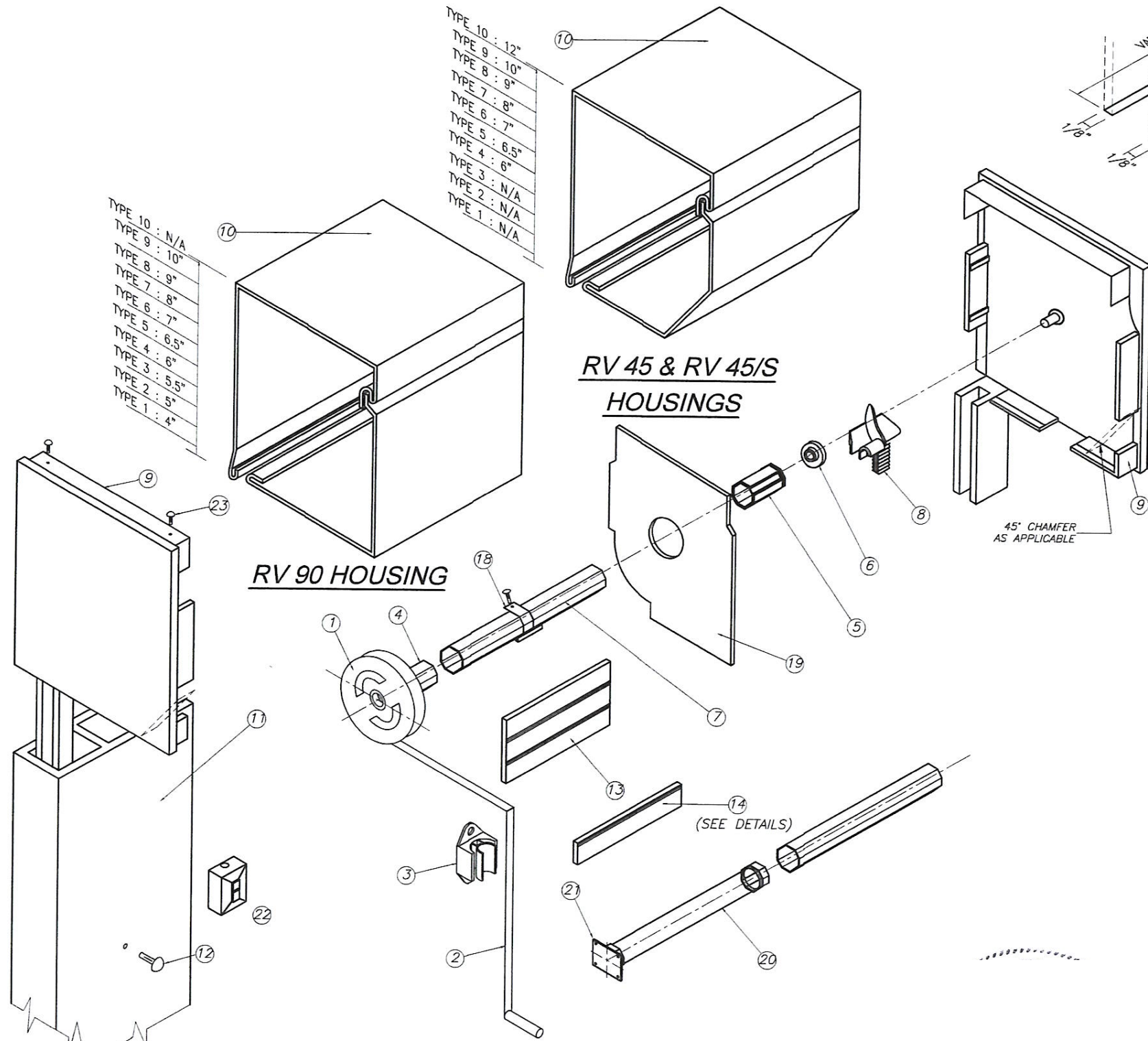

**M1 SIDE CAPS:**

COMPONENTS FOR GEAR OPERATED SYSTEM

- ① - GEAR
- ② - UNIVERSAL & CRANK
- ③ - CRANK HOLDER(OPTIONAL)
- ④ - GEAR INSERT(GEAR TO AXLE CONNECTOR)
- ⑤ - IDLER INSERT
- ⑥ - BALL BEARING
- ⑦ - OCTAGONAL AXLE \*
- ⑧ - ENTRY GUIDES
- ⑨ - SIDE/END CAP \*
- ⑩ - HOUSING(FRONT & BOTTOM), 0.040" THICK
- ⑪ - SIDE RAIL
- ⑫ - PLUG-BUTTONS
- ⑬ - ALUMINUM SLATS
- ⑭ - BASE SLAT
- ⑮ - PLASTIC STOPS(OPTIONAL)
- ⑯ - SIDE LOCKS(OPTIONAL)
- ⑰ - STAPLES(OPTIONAL)
- ⑱ - SPRINGLOCK HANGER
- ⑲ - SAFETY PLATES

ADDITIONAL COMPONENTS FOR MOTORIZED OPERATED SYSTEM

- ⑳ - TUBULAR MOTOR
- ㉑ - MOTOR BRACKET
- ㉒ - SWITCH

FASTENERS

- ㉓ - 3/16" ALUMINUM POP RIVETS(6 REQ'D EA. SIDE CAP) : 2 @ TOP, 2 @ REAR, 2 @ BOTTOM

\* SHALL BE CAPABLE TO SUSTAIN SLAT'S WEIGHT AND ASSURE LIFTING MECHANISM (SEE NOTE 9/1)

**M BOX COMPONENTS AND ASSEMBLY DETAIL**

END CAP SYSTEM  
(SEE NOTE 10 ON SHEET 1)



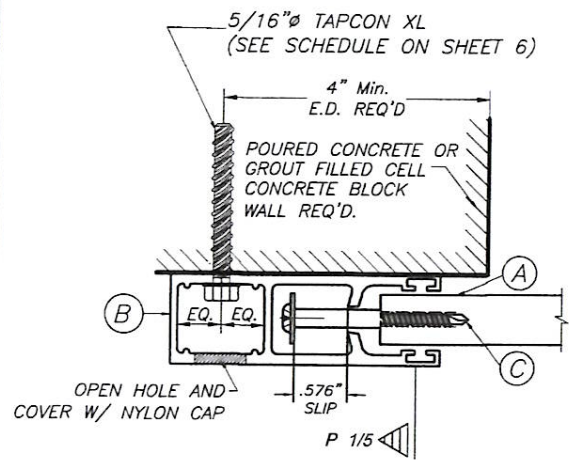

**SECTION P-P (1): WALL MOUNT**

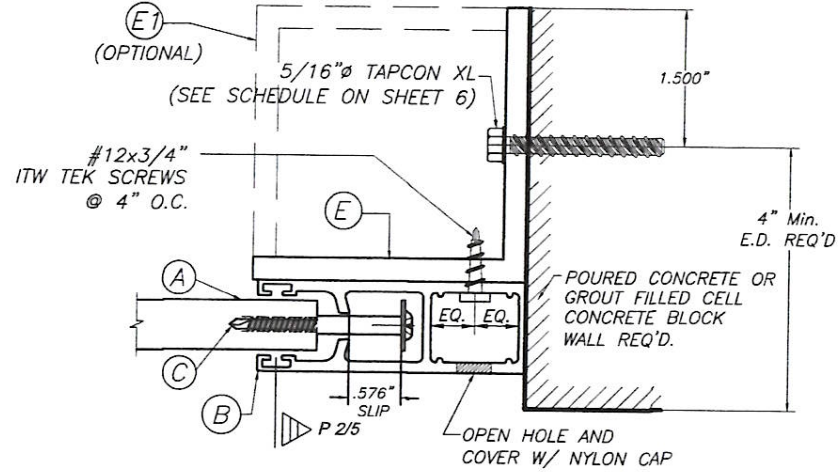

**SECTION P-P (2): INSIDE MOUNT**

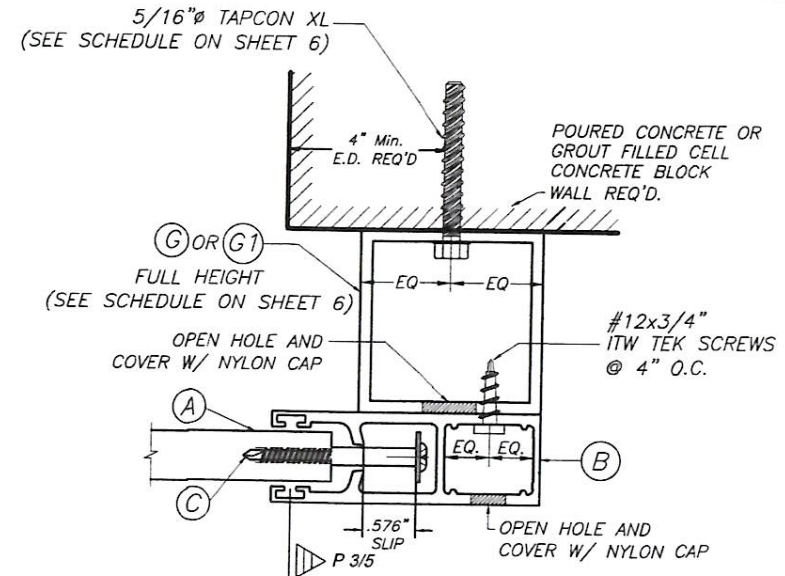

**SECTION P-P (3): BUILD-OUT**

**SIDE RAIL CONNECTIONS**

TO POURED CONCRETE OR GROUT FILLED CELL CONCRETE BLOCK WALL  
(SEE MAX. SLAT SPAN SCHEDULE ON SHEET 6)  
SCALE : 3/8" = 1"

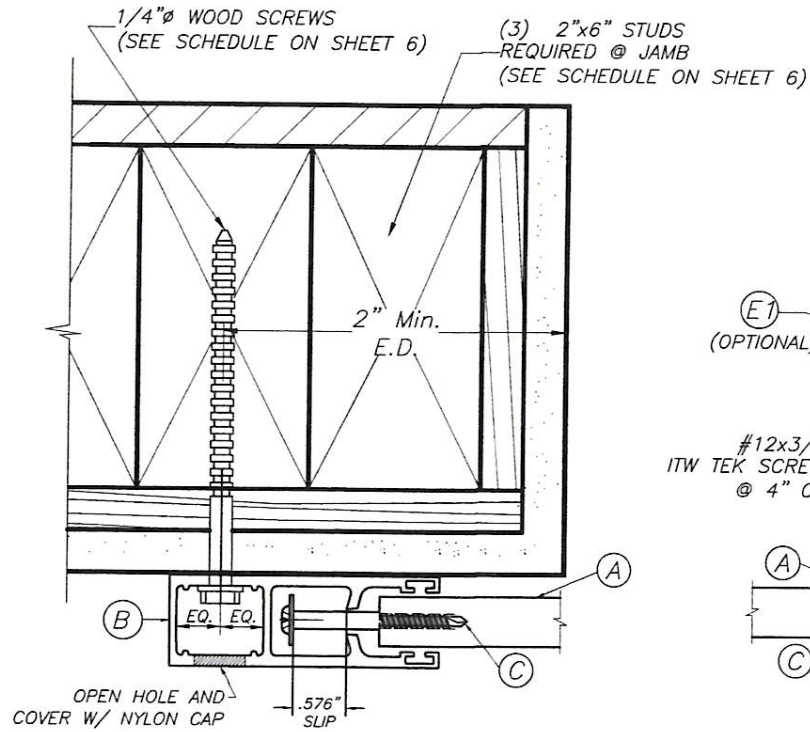

**SECTION P-P (1): WALL MOUNT**

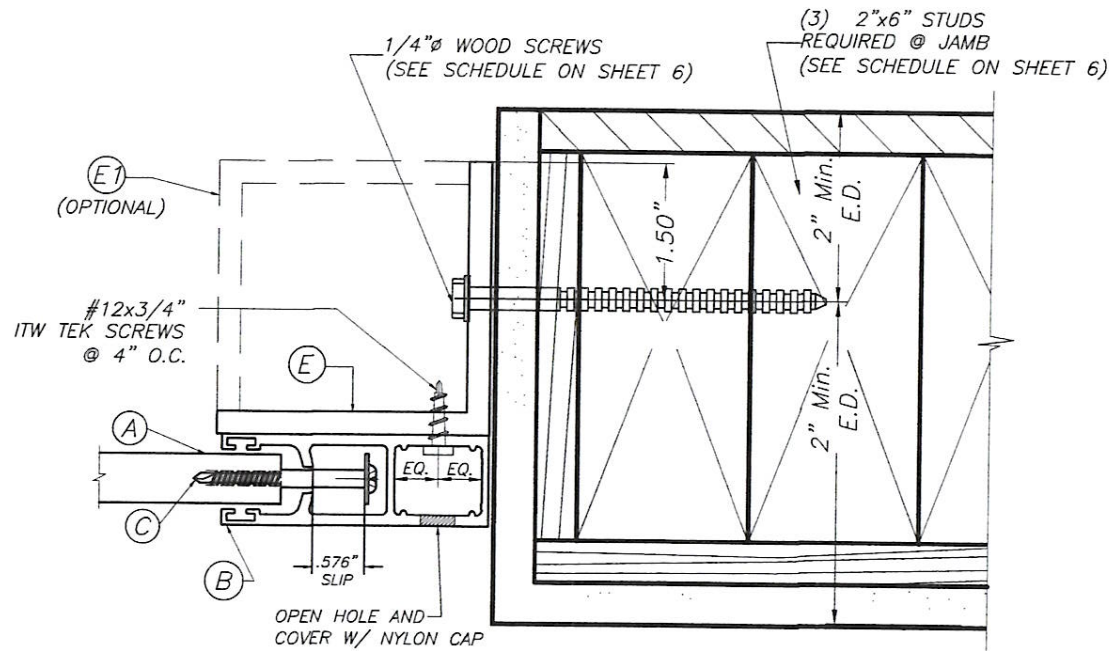

**SECTION P-P (2): INSIDE MOUNT**

**SIDE RAIL CONNECTIONS**

TO WOOD FRAME WALL  
(SEE MAX. SLAT SPAN SCHEDULE ON SHEET 6)  
SCALE : 3/8" = 1"

(3) 2"x6" STUDS REQUIRED @ JAMB (SEE SCHEDULE ON SHEET 6)  
1/4" WOOD SCREWS (SEE SCHEDULE ON SHEET 6)

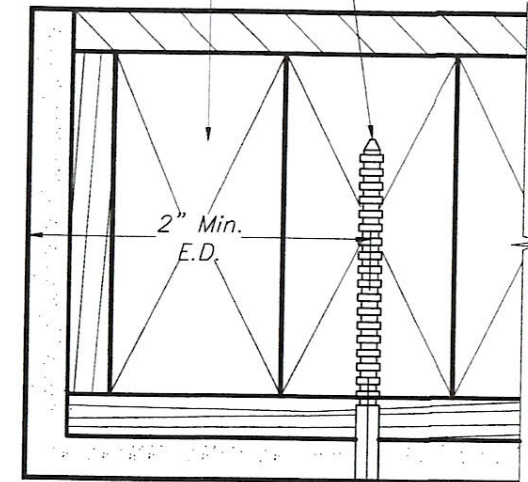

**SECTION P-P (3): BUILD-OUT**

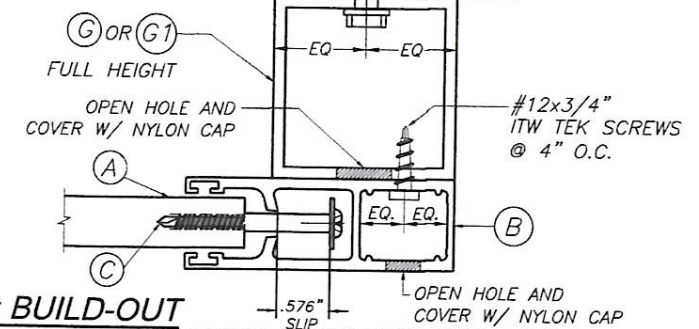
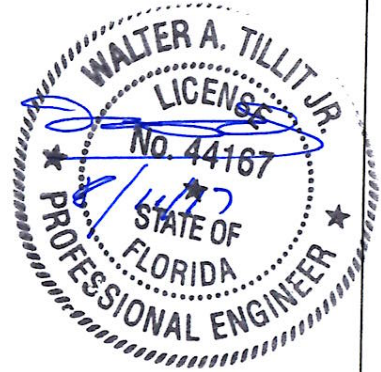

FLORIDA BUILDING CODE (High Velocity Hurricane Zone)



1"x2"x1/8" Alum. PLATE  
W/ 1/4"Ø TAPCON ANCHORS @ 12" o.c.

1"x2"x1/8" Alum. PLATE  
W/ 1/4"Ø TAPCON ANCHORS @ 12" o.c.

POURED CONCRETE  
REQUIRED

1"x2"x1/8" ALUMINUM TUBE  
W/ 1/4"Ø TAPCONS @ 12" o.c.  
1"x2"x1/8" Alum. PLATE  
W/ #14x3/4" S.M.S. @ 12" o.c.

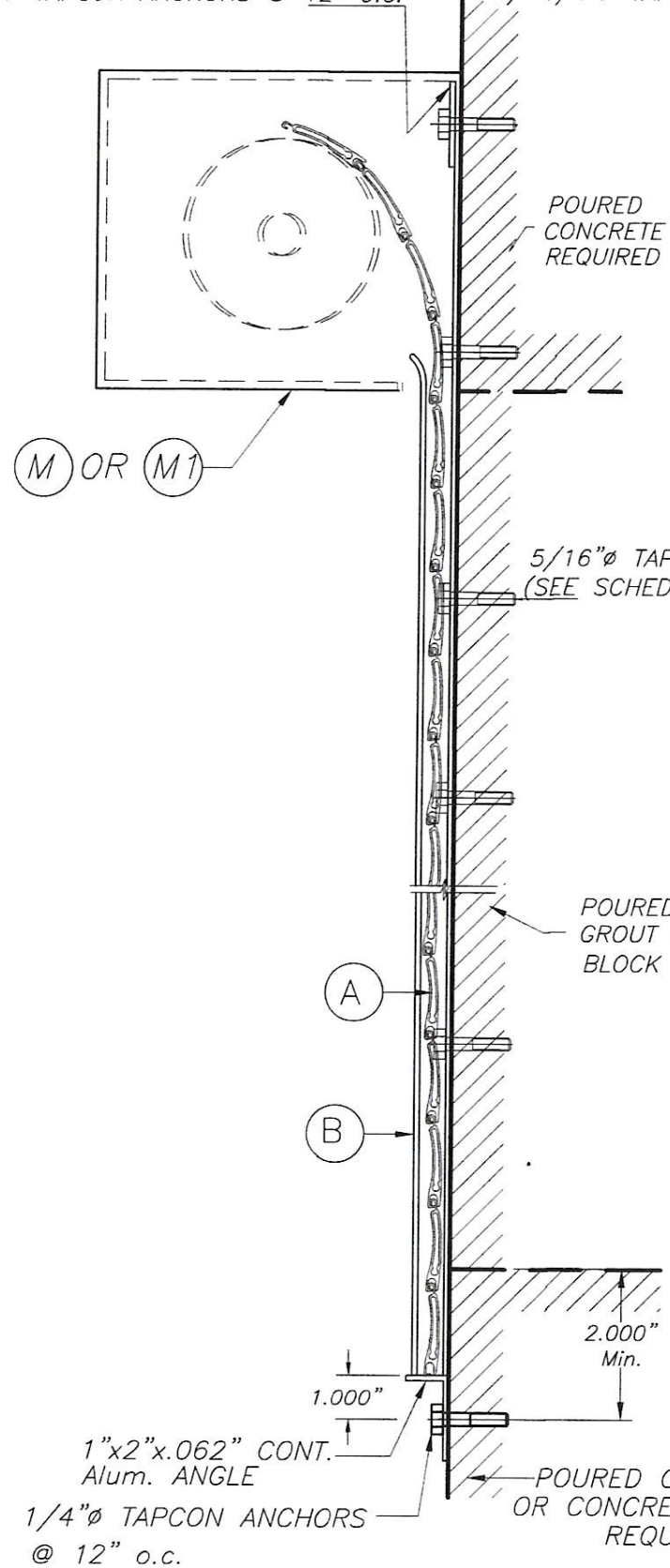

**SECTION P-P (1)**  
N. T. S.

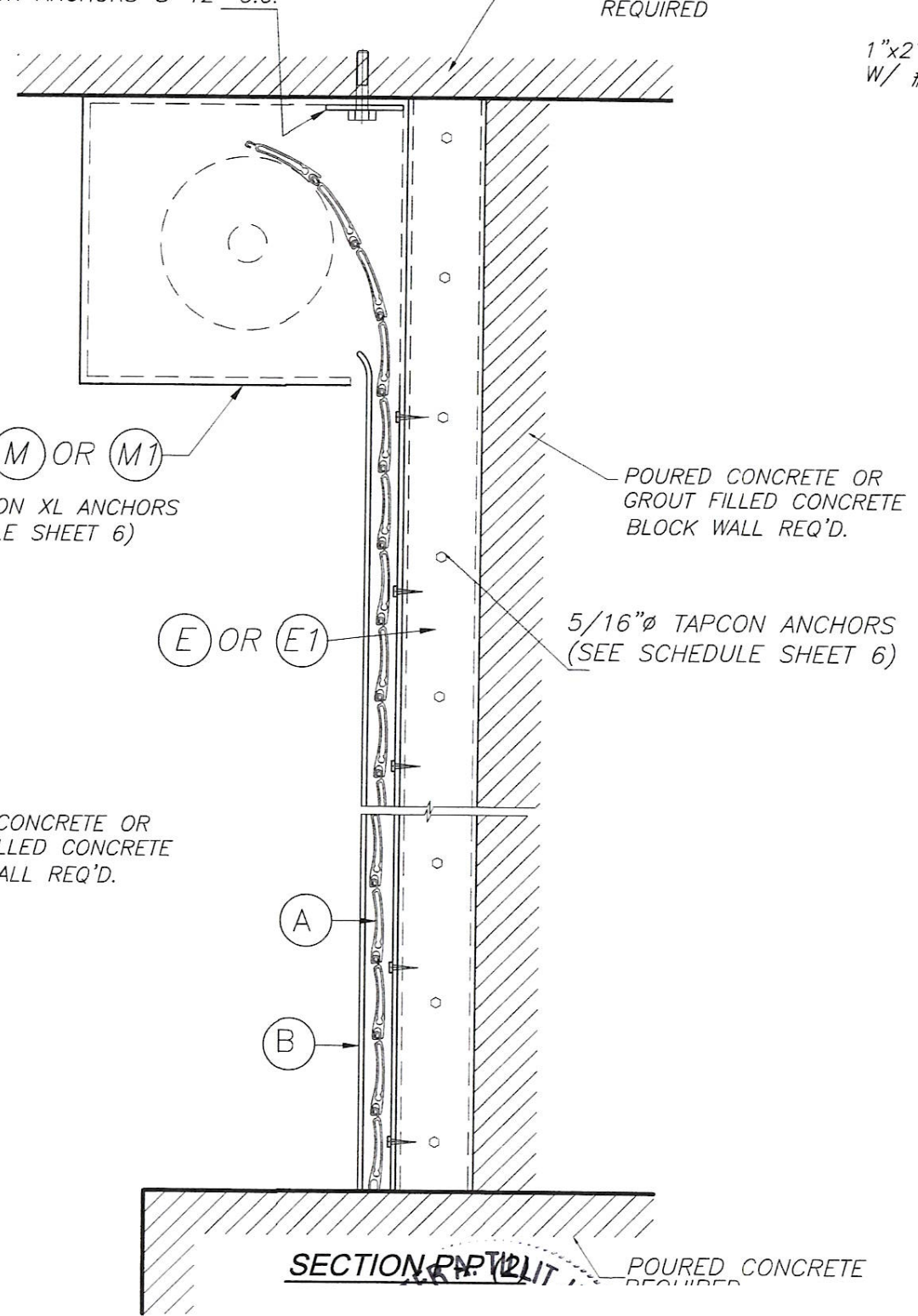

**SECTION P-P (2)**  
POURED CONCRETE  
REQUIRED

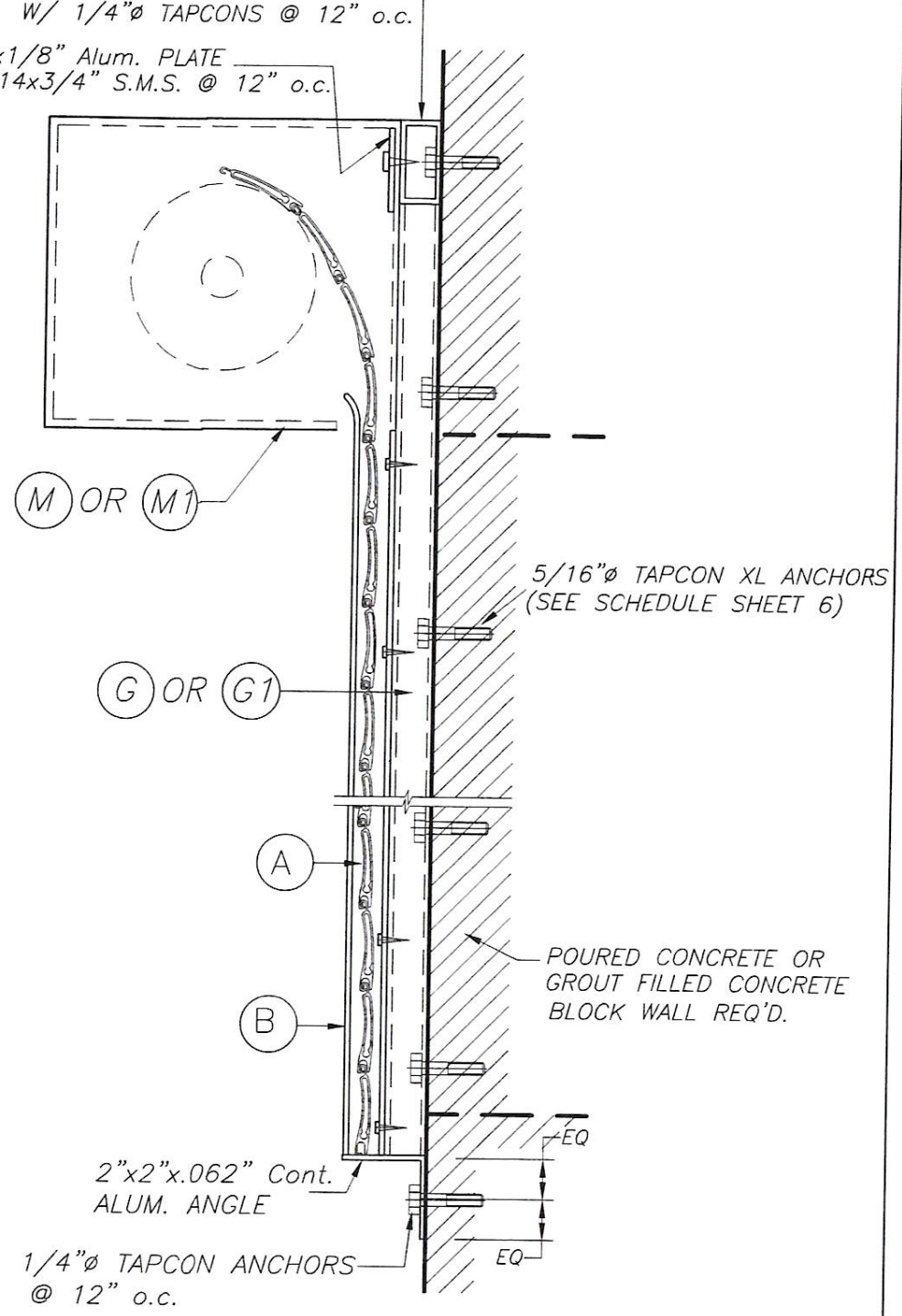

**SECTION P-P (3)**



**MAXIMUM SLAT SPAN "L" (ft) SCHEDULE.**

MAX. A.S.D. DESIGN PRESSURE RATING (p.s.f)	REQUIRED SUBSTATE	MAX. SPAN "L" (FT.)	REMARKS	SEPARATION *
+45, -45	POURED CONCRETE OR GROUT FILLED CONC. BLOCK.	12'-0"	SEE NOTE 8 ON SHEET 1	8"
	WOOD	12'-0"	SEE NOTE 8 ON SHEET 1	8"
+50, -50	POURED CONCRETE OR GROUT FILLED CONC. BLOCK.	7'-0"	SEE NOTE 8 ON SHEET 1	9 1/2"
	WOOD	7'-0"	SEE NOTE 8 ON SHEET 1	9 1/2"

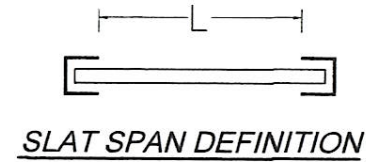

\*IN CASE PRODUCT IS USED AS AN HURRICANE ABATEMENT SYSTEM TO PROTECT THE BUILDING ENVELOPE, IT MUST BE INSTALLED AWAY FROM THE BUILDING COMPONENT TO BE PROTECTED NO LESS THAN MINIMUM SEPARATION INDICATED ON SCHEDULE.

**V<sub>x</sub> & V<sub>y</sub> REACTIONS AT JAMB.**

MAX. A.S.D. DESIGN PRESSURE RATING (p.s.f)	MAX. SLAT SPAN	REQ'D SLIP (In)	V <sub>x</sub> (Lb/Ft)	V <sub>y</sub> (Lb/Ft)
+45.0, -45.0	6'-0"	0.576"	255	135
	7'-0"	0.576"	385	158
	12'-0"	0.576"	971	270
+50.0, -50.0	6'-0"	0.576"	297	150
	7'-0"	0.576"	436	175
	12'-0"	N/A	N/A	N/A

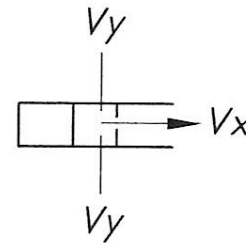

**MAXIMUM ANCHOR SPACING SCHEDULE FOR INSTALLATIONS INTO CONCRETE OR GROUT FILLED CONCRETE BLOCK.**

MAX. A.S.D. DESIGN PRESSURE RATING (p.s.f)	SPAN L (ft)	WALL MOUNTING		TRAPPED MOUNTING		BUILD-OUT MOUNTING	
		POURED CONCRETE	GROUT FILLED BLOCK	POURED CONCRETE	GROUT FILLED BLOCK	POURED CONCRETE	GROUT FILLED BLOCK
+45, -45	≤ 6'-0"	4"	4"	4"	4"	4"	4"
	>6'-0" TO 7'-0"	4"	4"	4"	4"	4"	4"
	>7'-0" TO 12'-0"	4"	4"	4"	4"	◇ 3 3/4"	◇ 3 3/4"
+50, -50	≤ 6'-0"	4"	4"	4"	4"	4"	4"
	>6'-0" TO 7'-0"	4"	4"	4"	4"	4"	4"

◇ REQUIRES INSTALLATION TO BE PERFORMED ONLY W/ (G1) (2"x3"x1/8") B.O. TUBE.

**MAXIMUM ANCHOR SPACING SCHEDULE FOR INSTALLATIONS INTO WOOD FRAME BUILDINGS.**

MAX. A.S.D. DESIGN PRESSURE RATING (p.s.f)	SPAN L (ft)	WALL MOUNTING		TRAPPED MOUNTING		BUILD-OUT MOUNTING	
		G=0.46	G=0.55	G=0.46	G=0.46	G=0.46	G=0.55
+45, -45	≤ 6'-0"	4"	4"	4"	4"	4"	4"
	>6'-0" TO 7'-0"	4"	4"	4"	4"	4"	4"
	>7'-0" TO 12'-0"	3"	3 1/2"	4"	4"	□ 2 1/2"	3 1/2"
+50, -50	≤ 6'-0"	4"	4"	4"	4"	4"	4"
	>6'-0" TO 7'-0"	4"	4"	4"	4"	4"	4"

□ ALTERNATIVELY, MAX. SPACING MAY BE 3" o.c. IF B.O. TUBE (G1) (2"x3"x1/8") IS USED IN LIEU OF (G) (2"x2"x1/8").