

Motor Adjustment Instructions 50 Series Motor

Limit Settings and Torque Settings

General Important Information

These motors are equipped with permanent overheating protection. When the motor "runs hot", followed by a cooling down phase, the motor will only switch on again if the operation switch has been switched to the neutral position for at least 20 seconds and the motor is sufficiently cooled.

Important Information

The position of the Studio Star shutter axle determines the shut-off in either direction via the crown. If the motor is not installed inside the axle, the crown does not move and the shut-off devices inside the motor do not function. These adjustment instructions picture an outside left motorized Studio Star; however, the same information applies to an outside right motorized shutter only the direction of adjustment for the buttons is reversed. A rule of thumb to remember when adjusting a Studio Star shutter is that the limit switch closest to you (the front of the housing) is the up adjustment; the switch towards the back of the housing is the down adjustment.

Adjusting the Motor Limits:

Down limit off point

Press in the adjusting switch all the way for the axle direction "down" and let it go when the lower position is reached.

If the motor runs further than desired at the lower position, return the Studio Star to the desired position and switch off your test cable. Push in the adjusting switch all the way for the axle direction "down" and check the lower position.

Upper shut-off point

Switch your test cable into the "up" position and press in the adjusting switch all the way on the motor for the axle direction "Up" and maintain the switch. This will allow the Studio Star Shutter to go up. ! Note: If the housing cover is off, ensure that the curtain is received by the guiderails correctly.

By switching off at the test cable, stop the shutter at the desired position. (You can also tap the "up" on your test cable to get the desired position).When the motor is switched off, press in the adjusting switch once more all the way for the axle direction "up".

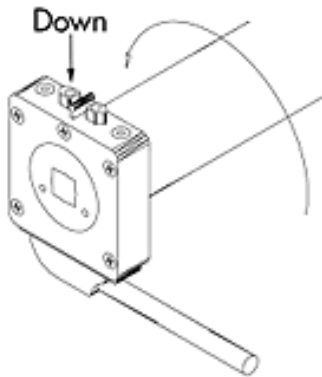

Move the shutter approx. 2 feet down and then up again in order to check the set position. If you missed the correct position in the "up" direction, let the shutter go to the correct position and press in the adjustment switch for the axle direction "Up". Now the exact position is set.

The limit switch adjustment can also be done in the opposite sequence, because the upper and lower positions are independent from each other.

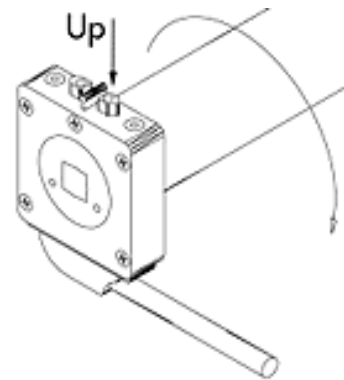

Important for Re-adjustment!!

ONLY press the switch of the axle rotational direction that is to be corrected! If the other switch is also pressed, then this point must also be re-adjusted!

Studio Star Motor Adjustment - Torque Settings for 50 Motors

All Studio Star shutters are pre-adjusted from the factory by a technician. Under proper operation, the shutter motor should switch off in the up-direction set position or if the shutter is blocked by an obstruction. In the down direction, the motor switches off in the down set position or will spin freely if obstructed. If it is necessary to change the torque settings, please note the placement of the torque screws and adjustment switches.

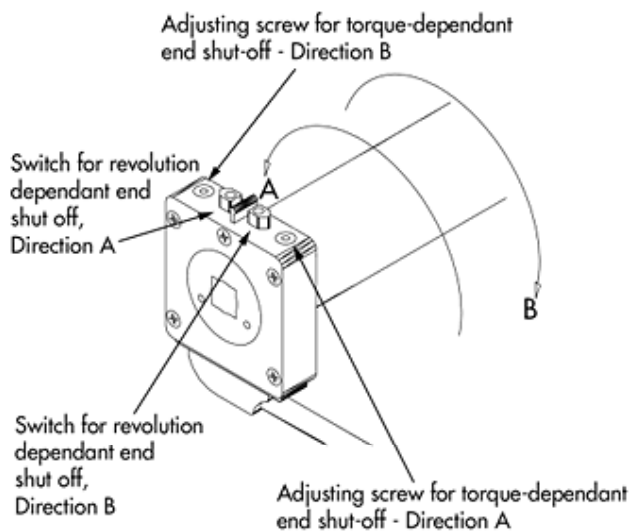

Torque Adjustment

First, run the Studio Star shutter up until it stops. Assuming that it doesn't go up all the way, keep the test switch in the up direction and maintain the "up" limit switch on the motor. The motor should now continue to move the shutter up. If possible, set the position for the "up" direction using the limit switch.

At this point, if the shutter still will not move all the way up, you will need to adjust the torque settings.

While maintaining the "up" direction on the test switch, hold in the limit switch in the direction of adjustment and turn the torque screw clockwise (use a 3mm allen wrench). Make sure that you are turning the torque screw corresponding to the direction of adjustment. When the shutter

is at the proper height, release the limit switch to set its position. After you have satisfactorily set the "up" limit, run the shutter down several inches using the test switch and then back up to ensure that it has set. At this point, you have already set the limit switch - do not change that. Check that the curtain will stop moving if obstructed by holding the top of the curtain while it runs up.

NOTE: Both the limit switch and torque settings are capable of stopping the shutter in the "up" position. It is very important that the LIMIT switch stops the motor from running and NOT the TORQUE setting. If the torque setting stops the curtain at its top position and NOT the limit switch, the shutter can be seriously damaged.

In the down direction, the torque adjustment is pre-adjusted from the factory also. In the case of an obstruction in the "down" direction, the motor will not shut off but the shutter will go into a "free spin". However, in the case of a shutter that makes excessive noise while going down, it is possible that the torque switch should be adjusted. Turn the appropriate torque screw clock-wise until the "clicking" noise stops.



Motor Adjustment Instructions 60 Series Motor

Limit Settings and Torque Settings

General Important Information

These motors are equipped with permanent overheating protection. When the motor "runs hot" followed by a cooling down phase, the motor will only switch on again if the operation switch has been switched to the neutral position for at least 20 seconds and the motor is sufficiently cooled.

Important Information

The position of the Studio Star shutter axle determines the shut-off in either direction via the crown. If the motor is not installed inside the axle, the crown does not move and the shut-off devices inside the motor do not function. Below is pictured the motor on its end: the direction that the adjustment switch will correspond to changes depending on which side of the shutter the motor is located. When looking at the end of the motor, the switch directions correspond to:

- 1) If the adjustment switch is tilted toward you (left side installation), then Direction 1 is up, Direction 2 is down.
- 2) If the adjustment switch is tilted away from you (right side installation), then Direction 1 is down, Direction 2 is up.

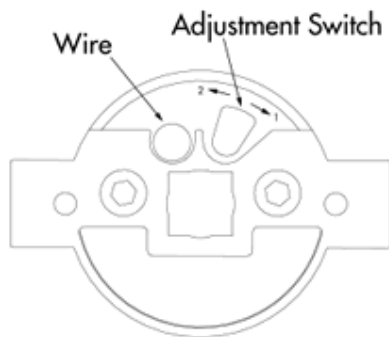

End View of Motor

Adjusting the endpoints

Down limit off point

Press the adjusting switch in the direction for the axle direction "down" and let it go when the lower position is reached.

If the motor runs further than desired at the lower position, return the Studio Star to the desired position and switch your test cable. Push in the adjusting switch all the way in the axle direction "down" and check the lower position.

Upper limit off point

Switch your test cable into the "up" position and press the adjusting switch in the direction that corresponds to the "up" direction of the shutter and maintain the switch. This will allow the Studio Star Shutter to go up. **Note: If the housing cover is off, ensure that the curtain is received by the guiderails correctly.** By switching off at the test cable, stop the shutter at the desired position. (You can also tap the "up" on your test cable to get the desired position).

Move the shutter approx. 2 feet down and then up again in order to check the set position. If you missed the correct position, (for example, 3" too high), let the shutter go to the correct position and press in the adjustment switch for the axle direction "Up". Now the exact position is set.

The limit switch adjustment can also be done in the opposite sequence, because the upper and lower positions are independent from each other.

Important for Re-adjustment!! ONLY press the switch in the direction that corresponds to the axle rotational direction that is to be corrected! If the switch is pressed the wrong way, then the other direction must also be re-adjusted!



Studio Star Motor Adjustm - Torque Settings for 60 Motors

All Studio Star shutters are pre-adjusted from the factory by a technician. Under proper operation, the shutter motor should switch off in the up-direction set position or if the shutter is blocked by an obstruction. In the down direction, the motor switches off in the down set position or will spin freely if obstructed. If it is necessary to change the torque settings, please note the placement of the nut and tension spring.

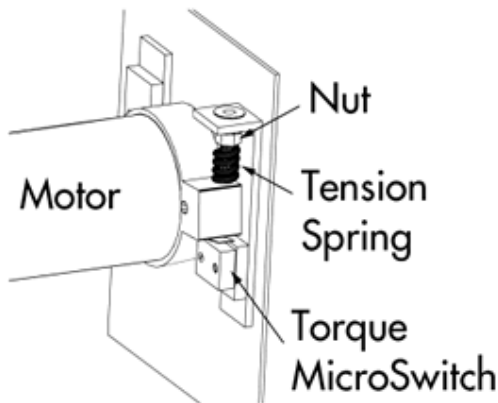

Torque Adjustment

First, run the Studio Star shutter up until it stops. Assuming that it doesn't go up all the way, keep the switch in the up direction and maintain the limit switch in the "up" direction on the motor. The motor should continue to move the shutter up. If possible, set the position for the "up" direction using the limit switch.

At this point, if the shutter still will not move all the way up, you will need to adjust the torque settings.

While maintaining the "up" direction on the test switch, push the limit switch in the direction that corresponds to the direction of adjustment and turn the nut clockwise viewed from above (placing more tension on the spring). When the shutter is at the proper height, release the limit switch to its position. After you have satisfactorily set the "up" limit, run the shutter down several inches using the test switch and then back up to ensure that it has set. At this point, you have already set the limit switch - do not change that. Check that the curtain will stop moving if obstructed by holding the top of the curtain while it runs up.

NOTE: Both the limit switch and torque settings are capable of stopping the shutter in the "up" position. It is very important that the LIMIT switch stops the motor from running and NOT the TORQUE setting. If the torque setting stops the curtain at its top position and NOT the limit switch, the shutter can be seriously damaged.

In the down direction, the torque does not have an adjustment. In the case of an obstruction in the "down" direction, the motor will not shut off but the shutter will go into a "free spin".